

**TRITON**



## **THAMES (Built-in)**

**Thermostatic  
concentric mixer  
shower**



**Installation  
and  
Operating  
Instructions**

INSTALLERS PLEASE NOTE THESE INSTRUCTIONS ARE TO BE LEFT WITH THE USER

<b>CONTENTS</b>	<b>Page</b>
Introduction	1
Safety warnings	1
Main components	2
Site requirements	3
Typical suitable installations	4 – 5
Getting started	6
Siting of the shower	6
Installation	7 – 8
Building-in depth	8
Solid wall, hollow wall and panel mounting	8 – 10
Fitting the bulkhead pipework	10
Leak testing	10
Making good	11
Fitting the trim plate	11
Bulkhead assembly	11 – 12
Fitting the riser rail	13 – 14
Fitting the hose and showerhead	14
Commissioning	15
Adjusting the maximum temperature setting	15
Adjusting the showerhead	16
Cleaning	17
Spare parts	18 – 19
Fault finding	20 – 21
Guarantee, service policy, etc.	rear cover

To check the product suitability for commercial and multiple installations, please contact Triton's specification advisory service before installation.

Telephone: +44 (0) 24 7632 5491

Facsimile: +44 (0) 24 7632 4564

E mail: [technical@triton.plc.uk](mailto:technical@triton.plc.uk)

### INTRODUCTION

This book contains all the necessary fitting and operating instructions for your Triton Thames concentric mixer shower. Please read them carefully. Read through the whole of this book before beginning your installation.

The shower installation must be carried out by a suitably competent person and in sequence of this instruction book.

Care taken during the installation will give a long and trouble free life from your shower.

For the best performance within the specified running pressure range a minimum flow of 8 litres per minute should be available to both inlets.

The mixer shower MUST NOT be subjected to water temperatures above 80°C. This mixer shower is designed for use with traditional low pressure 'gravity' water systems, using a cold water cistern and hot water cylinder as well as for the higher pressure systems found in the UK up to a maximum of 5 bar running pressure.

**IMPORTANT:** When installing this mixer with a combi boiler or multipoint water heaters, the supplied flow limiters must be installed in the inlet elbows.

This mixer shower is suitable for fully modulating type combination boilers and multipoint hot water heaters. It is also suitable for thermal storage, unvented systems and pumped gravity systems.

**IMPORTANT:** Before installing with a gas instantaneous water heater, make sure it is capable of delivering hot water at a minimum switch-on flow rate of 3 litres per minute. At flow rates between 3 and 8 litres per minute, the appliance must be capable of raising the water temperature to a minimum of 52°C. Water temperature at the mixer inlet must remain relatively constant when flow rate adjustments are made (*refer to the water heater operating manual to confirm compatibility with this mixer shower*).

This mixer shower is supplied with an integral large area filter in each inlet elbow. Inlet connections are by compression fittings for 15mm copper pipe.

### SAFETY WARNINGS

- a Layout and sizing of pipework MUST be such that when other services are used, pressures at the shower control inlets do not fall below the recommended minimum.
- b **DO NOT choose a position where the shower could become frozen.**
- c **DO NOT connect this mixer shower to any form of tap or fitting not recommended by the manufacturer.**
- d The showerhead MUST be regularly cleaned to remove scale and debris.
- e Conveniently situated isolating valves in each inlet supply MUST be fitted as an independent method of isolating the shower should maintenance or servicing be necessary.
- f If it is intended to operate the shower in areas of hard water (above 200 ppm temporary hardness), a scale inhibitor may have to be fitted. For advice on the Triton scale inhibitor, please contact Customer Service.
- g **DO NOT operate the shower outside the guidelines as laid out in 'site requirements'.**

Replacement parts can be ordered from Triton Customer Service. See 'spare parts' for details and part numbers.

Due to continuous improvement and updating, specification may be altered without prior notice.

MAIN COMPONENTS

Fig.1

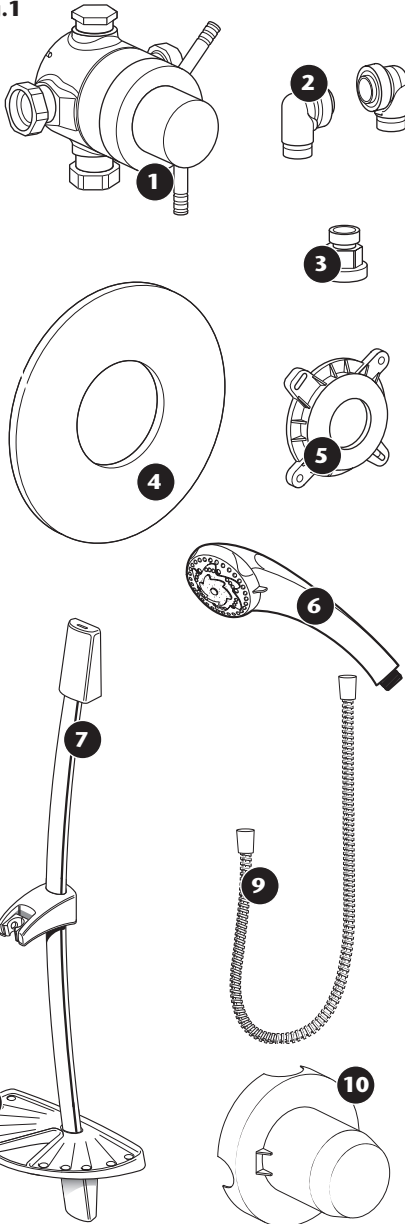

- 1** Mixer shower body
- 2** Inlet elbow
  - Flow limiters (HP systems only)
  - Spacer
  - Water filter
- 3** Outlet pipe connector
- 4** Trim plate
- 5** Fixing bracket
- 6** Showerhead
- 7** Riser rail kit
- 8** Soap dish
- 9** Shower hose
- 10** Tiling shroud
  - Nutted long thread connector
  - Bulkhead fitting

### SITE REQUIREMENTS

The installation must be in accordance with Water Regulations and Byelaws.

#### *Running water pressure:*

Gravity fed – 0.1 bar min.  
1.0 bar max.

Mains fed – 1.0 bar min.  
5.0 bar max.

#### *Maximum static water pressure:*

Gravity and mains – 10 bar

### **DO NOT connect the mixer shower to a gravity hot supply and a mains cold supply (or vice versa).**

For the best performance within the specified running pressure range a minimum flow of eight litres per minute should be available to both inlets.

While the mixer shower is operational (open outlet), inlet pressures must not be capable of exceeding 7 bar. For effective operation of the internal seals, the maximum static pressure must not be exceeded.

**Note:** On sites where the running pressure is above 5 bar, the use of a suitably sized pressure reducing valve fitted in the cold mains supply pipework can provide nominally equal pressures at the mixer shower.

The pipework should be installed such that the flow is not significantly affected by other taps and appliances being operated elsewhere on the premises.

**Note:** Where thermal store systems and instantaneous gas water heaters are used, if excessive draw offs take place the boiler may not be able to maintain an adequate output temperature. This could result in the shower temperature becoming noticeably cooler.

### Water temperature requirements

Maximum hot water temperature: 80°C

Recommended maximum: 65°C

Minimum hot water temperature: 52°C

Maximum cold water temperature: 20°C

BS 6700 recommends that the temperature of stored water should never exceed 65°C.

A stored water temperature of 60°C is considered sufficient to meet all normal requirements and will minimise the effects of scale in hard water areas.

### Temperature adjustment range

The mixed water temperature can be adjusted from cold through to a top limit which must be pre-set during installation with full anti-scald protection throughout the range (35°C to 40°C) providing the hot water temperature at the inlet remains 10°C above the outlet temperature.

**Fig.2** (diagrammatic view – not to scale)

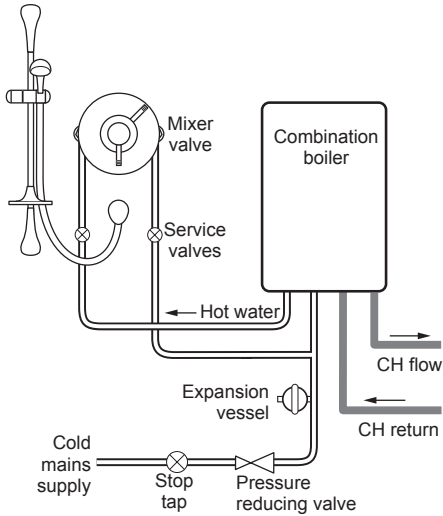

**TYPICAL SUITABLE INSTALLATIONS**

**a) Instantaneous gas-heated systems, e.g. combination boilers (fig.2)**

The shower control must be installed with a multipoint gas water heater or combination boiler of a fully modulating design (i.e. to maintain relatively stable hot water temperatures).

A drop tight pressure reducing valve must be fitted if the supply pressures exceed 5 bar running.

An expansion vessel, shown in (fig.2), MUST be fitted, and regularly maintained, to stop the shower mixer being damaged by excess pressures. This may already be installed within the boiler (check with manufacturer) and is in addition to the normally larger central heating expansion vessel.

The layout and sizing of pipework MUST be such that nominally equal inlet supply pressures are achieved and the effects of other draw-offs are minimised. The hot supply temperature MUST remain a minimum of 10°C hotter than the required blend temperature for best performance.

**Fig.3** (diagrammatic view – not to scale)

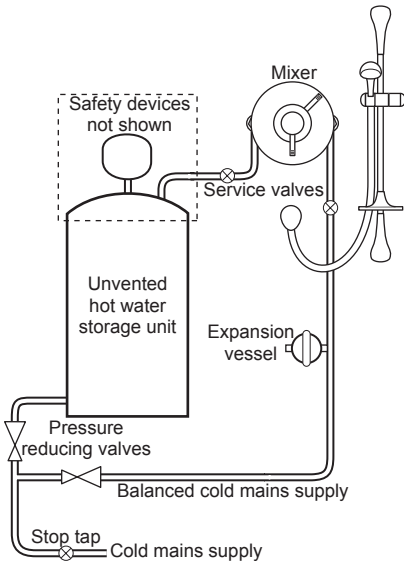

**b) Unvented mains pressure systems (fig.3)**

The shower control can be installed with an unvented, stored hot water cylinder.

For systems with no cold water take off after the appliance reducing valve, it will be necessary to fit an additional drop tight pressure reducing valve when the mains pressure is over 5 bar. The drop tight pressure reducing valve must be set at the same value as the unvented package pressure reducing valve.

**Note:** An additional expansion vessel (fig.3) may be required if a second pressure reducing valve is installed. This does not apply to packages with a cold take off after the pressure reducing valve to the cylinder.

The layout and sizing of pipework MUST be such that nominally equal inlet supply pressures are achieved and the effects of other draw-offs are minimised.

**c) Mains pressurised thermal store systems (fig.4)**

Packages of this type, fitted with a tempering valve (blender valve) can be used. A drop tight pressure reducing valve must be fitted if the supply pressures exceed 5 bar running.

An expansion vessel, shown in (fig.4), MUST be fitted, and regularly maintained, to stop the unit being damaged by excess pressures. This may already be installed externally or internally within the thermal store (check with thermal store manufacturer).

**d) Gravity fed systems (fig.5)**

The shower control MUST be fed from a cold water cistern and hot water cylinder providing nominally equal pressures. There must be a minimum of one metre head of water. The minimum head distance is measured from the base of the cold water cistern to top of the shower head (fig.5).

**e) Pumped gravity fed systems (fig.6)**

The shower control can be used with a gravity fed system in conjunction with a pump to boost pressures as shown (fig.6).

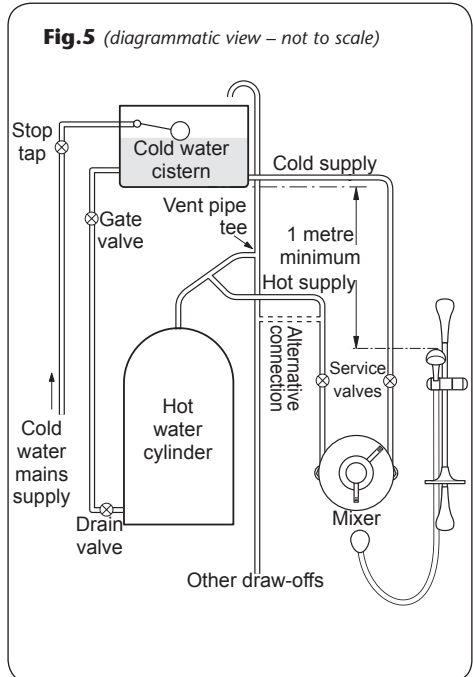
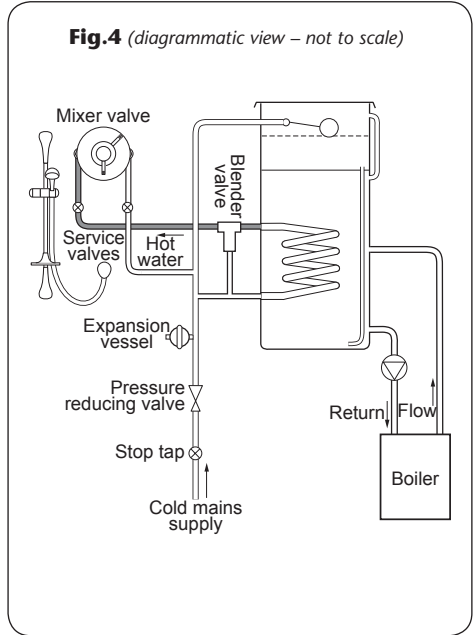

**Fig.6** (diagrammatic view - not to scale)

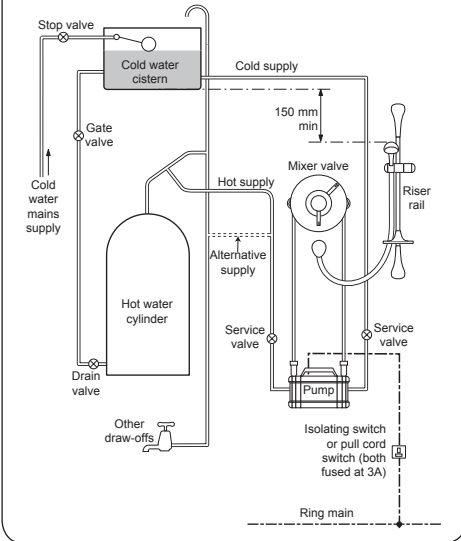

**Fig.7** (diagrammatic view – not to scale)

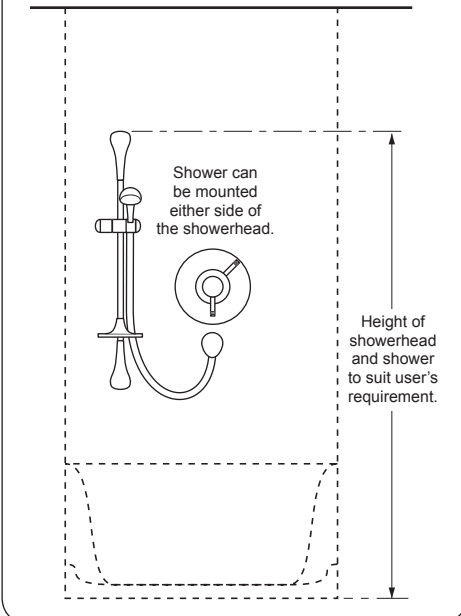

## GETTING STARTED

Check the contents to make sure all parts are present.

Before installing, make sure all the openings on the mixer are carefully covered to prevent ingress of any debris etc. The mixer body is supplied with caps in the inlet and outlet openings. Leave these in place during building work, etc. and remove only when the final connection is required.

The hot and cold water pipes should not be permanently attached to the wall closer than 25mm from the mixer before installation to allow final adjustment of the mixer unit position.

## SITING OF THE SHOWER

### WARNING!

**The shower must not be positioned where it will be subject to freezing conditions.**

Refer to **(fig.7)** for correct siting of the shower.

Position the shower and showerhead on the wall so that all controls can be comfortably reached while using the shower. The showerhead and riser rail can be positioned either side of the shower.

It is advised to position the bulkhead about 150mm to 250mm below the mixer and in line with the outlet port. When planning the bulkhead position, make sure the hose will not restrict the full vertical movement of the showerhead on the riser rail.

**IMPORTANT:** The hot entry port is on the left-hand side of the mixer body **(fig.8)** marked in red.

## INSTALLATION

### General conditions

**Note:** The outlet of the shower MUST NOT be connected to anything other than the hose and showerhead supplied.

DO NOT use jointing compounds on any pipe fittings for the installation.

Use only the compression fittings supplied.

DO NOT solder fittings near the mixer unit as heat can transfer along the pipework and damage seals and thermostatic components.

**Note:** Suitable isolating valves (complying with Water Regulations and Byelaws) MUST be fitted on the hot and cold water supplies to the shower as an independent means of isolating the water supplies should maintenance or servicing be necessary.

When connecting pipework avoid using tight 90° elbows. Swept or formed bends will give the best performance.

**IMPORTANT:** The water circuit should be installed such that the flow is not significantly affected by other taps and appliances being operated elsewhere on the premises. Water pressure must not fall below specification of the shower.

**Hot water pipe entry must be made to the left-hand side inlet.**

**IMPORTANT:** The mixer inlet elbows contain filters that may become blocked if debris is not flushed through before fitting.

The inlet elbows allow for either rising, falling or rear entry hot and cold water supplies. The elbows have water filter inserts, complete with seals (**fig.9**), and do not require PTFE tape or other means of sealing.

### High pressure systems

If installing the mixer with a high pressure system the two flow limiters supplied MUST be inserted into the inlet elbows. To fit, insert the flow limiter and washer into the mixer body inlet (**fig.10**). Carefully screw the elbow in place, making sure the water filter is fitted correctly.

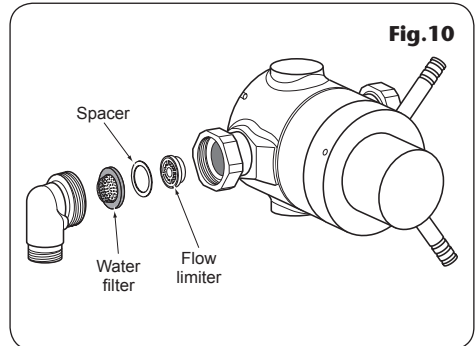
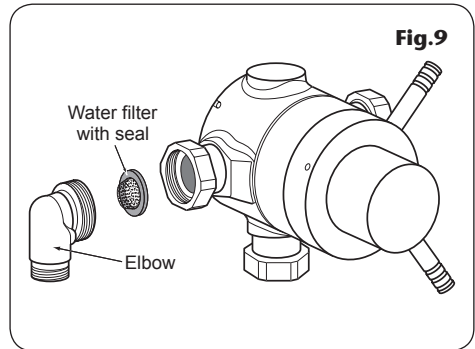
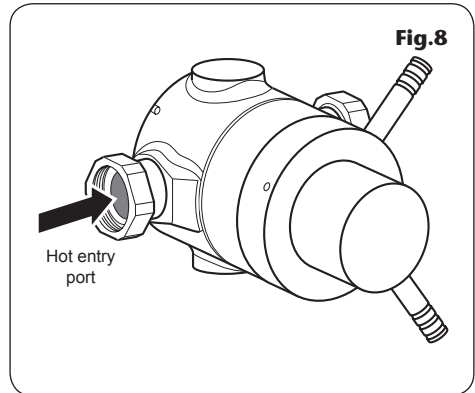

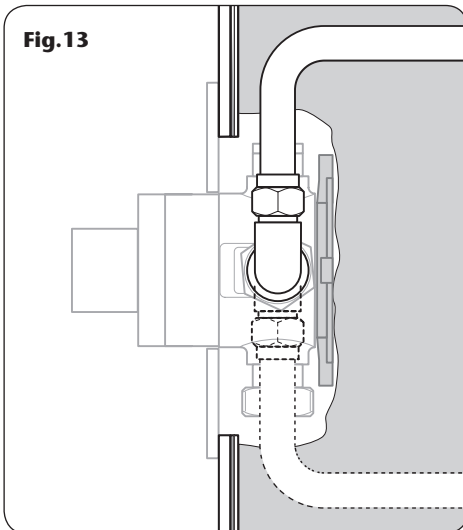
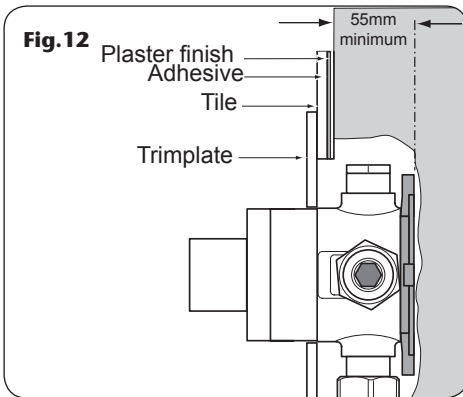
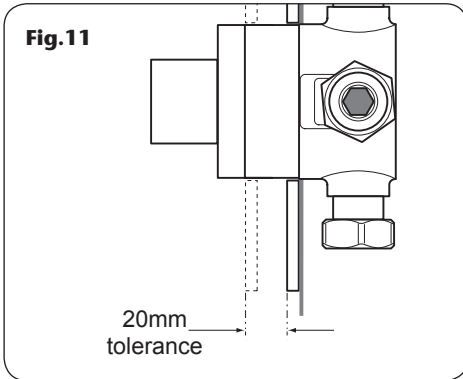

### Instantaneous gas water heaters

For best performance from the shower when connected to an instantaneous water heater, the appliance must be capable of raising the temperature of the incoming water to a minimum of 52°C (125°F) and delivering a flow rate of not less than eight litres per minute.

With the flow limiters fitted and when the system is in use, the On/Off flow control should be turned fully anti-clockwise to full flow setting.

### BUILDING-IN DEPTH

The allowance for varying thicknesses of tiles up to 10mm is accommodated by the front trim plate (**fig 11**). The maximum tolerance between the trim plate and mixer body is 20mm.

The following are typical thicknesses and are given as a guide only:

Tile	6 – 10mm
Adhesive	2 – 3mm
Plasterboard	9.5 – 12.5mm
Plaster finish	2 – 3mm

Maximum tile thickness to be 10mm.

When installing into a stud partition or other hollow wall structure, the installer may wish to consider building rear supports or other options for fitting the fixing bracket. Such options are beyond the scope of this guide.

Use the supplied tiling shroud as a template when cutting the opening for installing the shower into a solid wall, stud partition or hollow wall structure.

If using the fixing bracket in a solid wall (**fig.12**), make sure the available building-in depth is at least 55mm measured from the face of the wall.

### SOLID WALL, HOLLOW WALL AND PANEL MOUNTING

The building in depth for the fixing bracket is typically 55mm from plaster finish but this is dependant upon tile and adhesive thicknesses.

Decide upon the shower position and determine whether the hot and cold water supplies will enter from the top (falling), bottom (rising) or

rear.

**Note:** For the rear entry supplies, in order to access the inlet elbow compression fitting (**fig.13**), it is advisable to have the pipework rising or falling from the elbows before routing to the rear.

Using the tiling shroud supplied, mark the hole outline position onto the wall (**fig.14**). Remove the plaster and brickwork (or plasterboard) to the depth required and chase out any additional areas of wall to allow for incoming pipework and access to the mixer and the outlet pipework to the bulkhead.

The final separation between pipe centres needs to be 170mm (**fig.15**).

Offer the fixing bracket up to the wall. Centralise and mark the four holes.

Drill and plug the holes using the wall plugs provided (*the wall-plugs provided are suitable for most brick walls – use an appropriate masonry drill, but if the wall is plasterboard or a soft building block, use special wall-plugs and a suitable drill bit*).

**Note:** It is preferable to flush the pipework (fig.16) to clear the system of debris and check for leaks before connecting to the mixer.

**IMPORTANT:** The mixer inlet elbows contain water filters that may become blocked if debris is not flushed through before fitting.

Remove the plugs from the mixer valve inlets and outlet. Fit the outlet adaptor for connection to the bulkhead.

Make sure the inlet elbows are facing the correct way. Offer the mixer up to the fixing bracket, fit and secure using the grub screws provided.

Complete the pipework to the mixer valve marking off the length to enter the elbows.

**Note:** Enough free play must be left in the pipework to allow withdrawal from the compression fittings.

**DO NOT secure the incoming pipes within one metre of the shower mixer.**

Remove the mixer and cut the pipes to length.

Refit the mixer to the fixing bracket and pipework. Slide the inlet nut and olives onto the supply pipes.

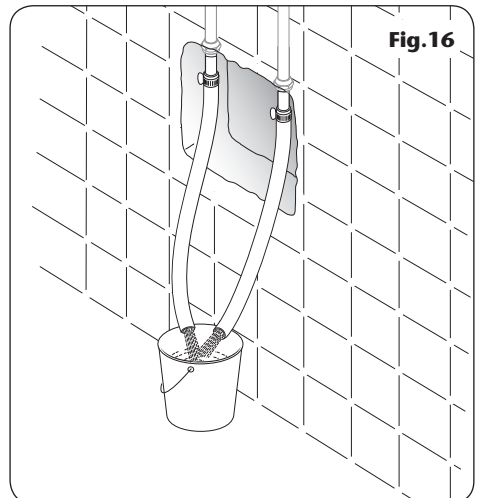
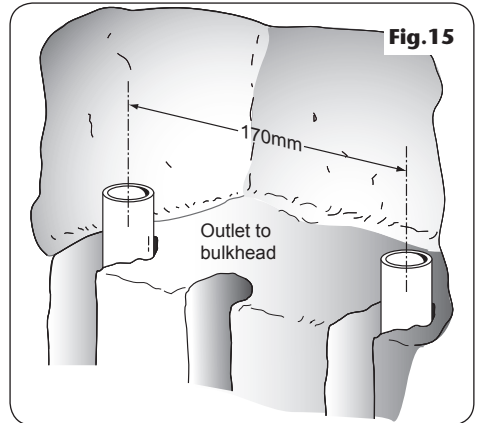
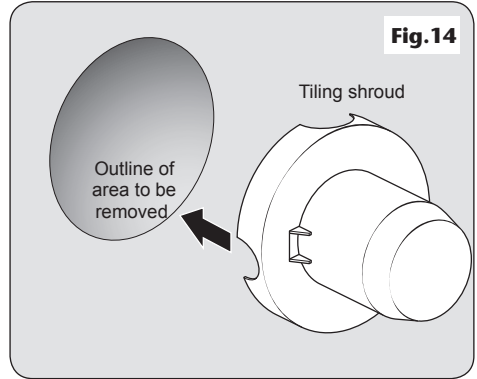

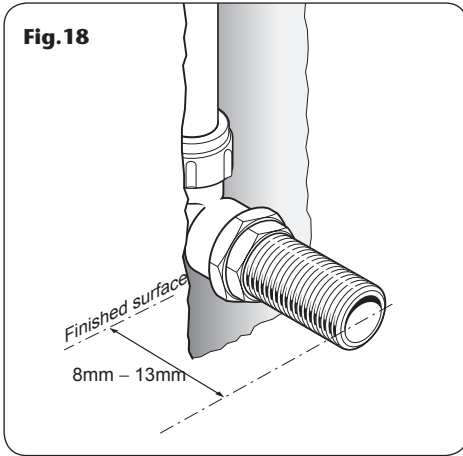
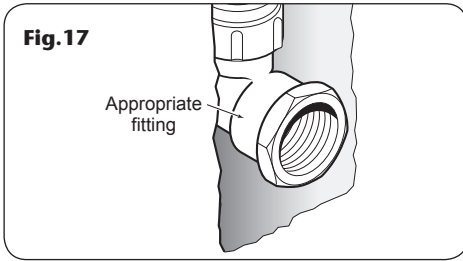

Tighten the inlet nuts and valve body grub screws.

### FITTING THE BULKHEAD PIPEWORK

Complete the outlet pipework ending in a 15mm x 1/2" BSP female thread elbow (**fig.17**).

**Note:** This fitting is not supplied as variations in installations require the selection of a suitable solder or compression fitting.

Screw the supplied male-thread connector into the female fitting (**fig.18**) using PTFE tape to give a watertight joint.

**Note:** The male-thread connector supplied has a shoulder. If fitting into a flush wall, make an additional 8mm allowance for this shoulder at the finished surface. The connector can be cut to size if required.

The threaded connector should protrude from the finished wall surface between 8mm and 13mm.

### LEAK TESTING

Fit a hose to the bulkhead threaded connector and direct it to waste.

Turn the flow control fully clockwise to close it. Open the isolating valves to the shower. Open the flow control by turning fully anti-clockwise and flush through.

Turn the temperature control fully anti-clockwise (HOT) and then fully clockwise (COLD).

Turn the flow control fully clockwise to close off the water supply.

Check for any leaks and remedy if necessary.

TURN OFF the water supplies.

### MAKING GOOD

Place the tiling shroud over the shower mixer and secure temporarily. Make good the incoming and outlet pipe channelling and around the bulkhead outlet. Plaster or tile up to the edge of the shroud.

**Note:** The tiles must be accurately cut to match the profile of the shroud. The outer cover will then accurately seal the hole, and enable the mixer unit to be removed from the mounting bracket without the need to break any tiles.

Make sure the grout lines are flush with the tiles to provide a smooth sealing surface for the outer cover. When complete, remove the tiling shroud.

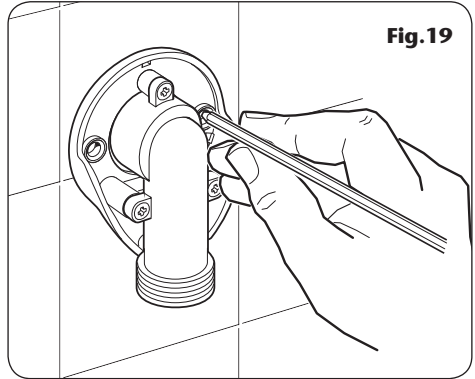

### FITTING THE TRIM PLATE

Fit the trim plate over the protruding controls and slide tight to the wall. Make sure the seal in the opening stays in place as it slides over the valve body. A smear of liquid soap on the seal will ease this procedure.

The trim plate incorporates a silicon sponge backing that seals against a smooth wall.

### BULKHEAD ASSEMBLY

Screw the bulkhead elbow to the bulkhead body with the three screws supplied.

Screw the completed assembly onto the threaded connector temporarily to mark the position of the two fixing holes (**fig. 19**) for securing the bulkhead to the wall.

**Note:** If screw thread protrudes too far out of the wall, it can be cut to the correct length using a hacksaw.

Unscrew and remove the bulkhead assembly. Check the location of the pipe in the wall before drilling.

Drill and plug the holes using the wall plugs supplied. *(The wall-plugs provided are suitable for most brick walls – use an appropriate masonry drill, but if the wall is plasterboard or soft building block, you must use special wall-plugs and a suitable drill bit).*

If fitting to a hollow wall structure, it may be preferable to secure the bulkhead by applying a

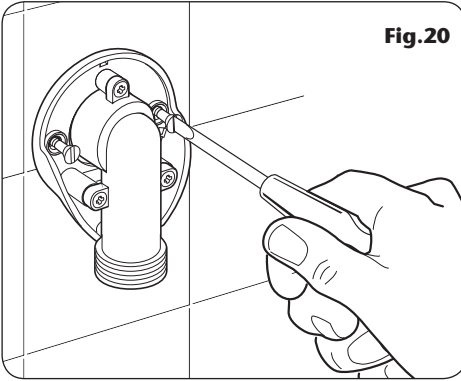

bead of silicon seal to the back of the bulkhead.

Apply PTFE tape to the threaded connector.

Screw the bulkhead assembly onto the threaded connector until tight to the wall and the two fixing holes are aligned. Secure to the wall with the two screws supplied (**fig.20**).

Finish by clipping the cover onto the bulkhead, making sure the protruding legs locate in the bulkhead body.

At this point, refer to the '*commissioning procedure*' in order to establish the correct maximum shower temperature.

## FITTING THE RISER RAIL

### WARNING!

**Check there are no hidden cables or pipes before drilling holes for wall plugs. Use great care when using power tools near water. The use of a residual current device (RCD) is recommended.**

Decide the position for the rail on the wall within the shower area. Proceed as follows:

Fit the showerhead holder onto the riser rail. The correct position of the holder is when the showerhead holder is sloping **DOWN** (**fig.21**).

To fit the showerhead holder onto the riser rail unit, press and hold the button on the underneath of the showerhead holder to release the locking mechanism, then slide onto the rail.

Slide the supplied soap dish onto the riser rail below the showerhead holder (**fig.22**).

Slide the top and bottom finishing trims onto the riser rail (**fig.23**).

Push the two fixing brackets into the ends of the riser rail (**fig.24**).

Offer the rail assembly to the wall (**fig.25**).

Using the brackets as templates, mark two upper holes and two lower holes. Note there are four provisions for screws per bracket – select the two most suitable for your requirements. Make sure the rail is aligned vertically.

Drill and plug the wall. (*The wall-plugs provided are suitable for most brick walls – use an appropriate masonry drill, but if the wall is plasterboard or a soft building block, use special wall-plugs and a suitable drill bit.*)

Screw to the wall with the fixing screws supplied.

Slide the finishing trims onto the brackets. Make sure the lug on each rail bracket end engages into the slot on the fatter end of each trim before push fitting the thinner ends in place (**fig.26**).

To remove a trim, push a small screwdriver or similar through the slot in the trim end and

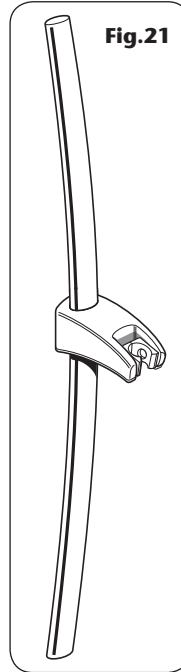

Fig.21

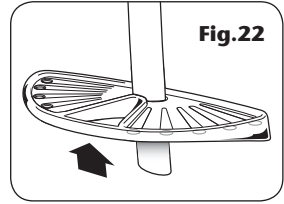

Fig.22

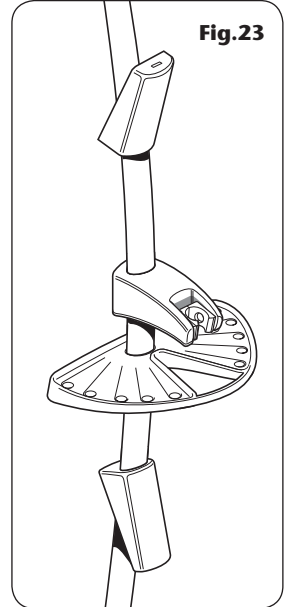

Fig.23

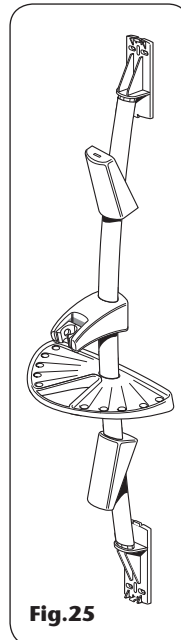

Fig.25

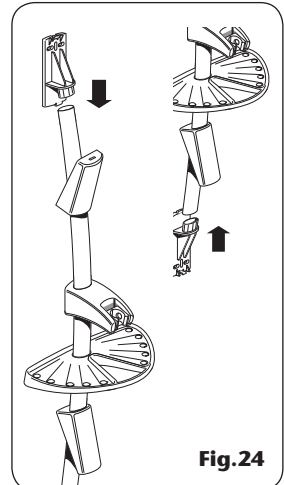
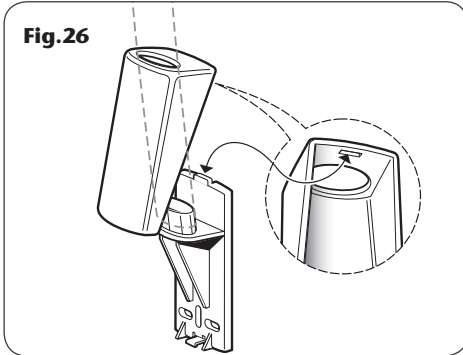

Fig.24



carefully pull away from the wall bracket.

Slide the soap dish down the rail so that its bracket engages on top of the lower finishing trim.

### Adjusting the showerhead holder

To adjust the height, press the button underneath the holder to release the locking mechanism (**fig.27**). Still pressing the button, move the holder up or down to suit user's requirement.

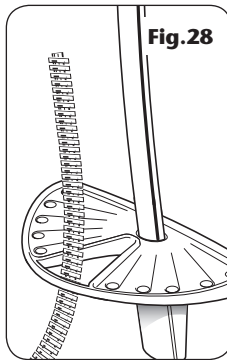
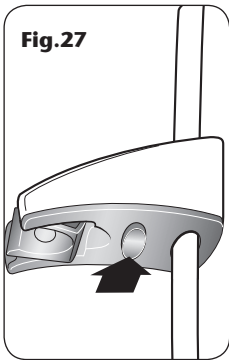

### FITTING THE HOSE AND SHOWERHEAD

Feed the flexible hose through the soap dish opening (**fig.28**) so the dish acts as a retaining ring (Water Regulations).

Screw the flexible hose to the shower outlet and showerhead, making sure the supplied washers are in place at both ends of the flexible hose (**fig.29**).

Place the showerhead into the holder and check that it fits correctly (**fig.30**).

**Note:** The holder is slightly tapered and the showerhead and hose will only fit from one direction.

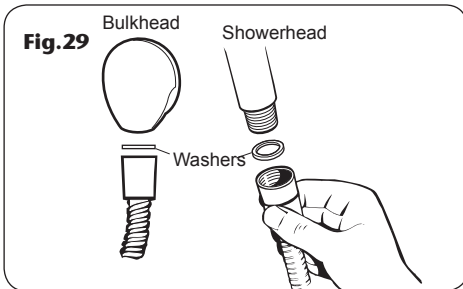

**IMPORTANT:** It is the conical end of the hose which grips into the holder. The showerhead will not fit in the holder without the hose attached.

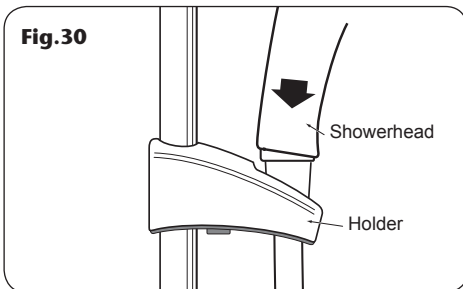

## COMMISSIONING

**Make sure that all supply pipework has been flushed through before commissioning.**

Check that both hot and cold water supplies are fully open and at (or near to) their design temperature and pressures are within the requirements as stated.

Make sure the temperature control is at the maximum temperature setting and direct the showerhead to waste.

Start the water flow by turning the flow control anti-clockwise. Allow the shower to run at the maximum temperature setting until the water temperature has stabilised. Rotate the temperature control knob anti-clockwise until the desired maximum showering temperature is reached.

The mixers have a temperature stop to prevent accidental rotation to higher water temperatures. This is adjustable to provide a maximum temperature of 35°C – 45°C.

## ADJUSTING THE MAXIMUM TEMPERATURE SETTING

Remove the temperature control by first removing the temperature lever and then loosening the grub screws (**fig.31**).

Turn the flow control fully anti-clockwise. With a steady flow running, adjust the spindle on the temperature valve by hand until the temperature is at the desired setting (clockwise for cooler and anti-clockwise for hotter).

When you are satisfied with the temperature turn the flow control off.

Carefully refit the temperature control so that the pin on the inside of the control butts up to the stop on the valve itself (**fig.32**).

Secure the control using the grub screws and refit the temperature lever.

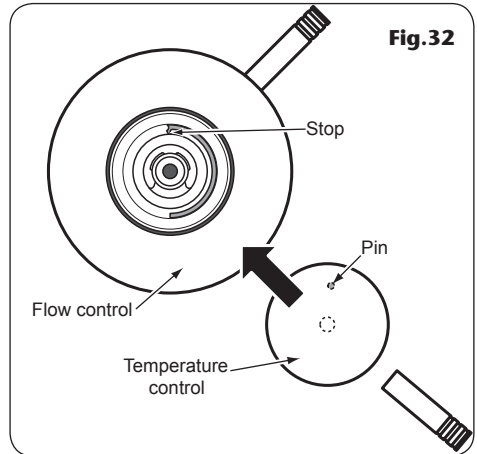
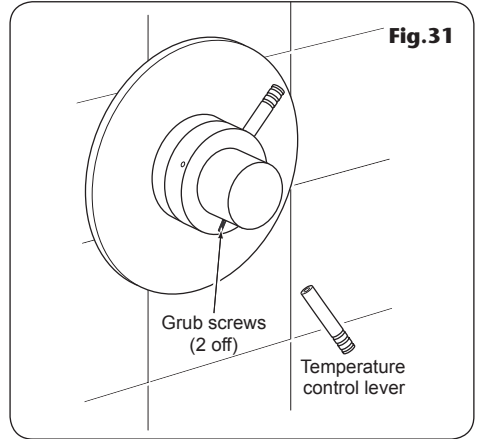

**Fig.33**

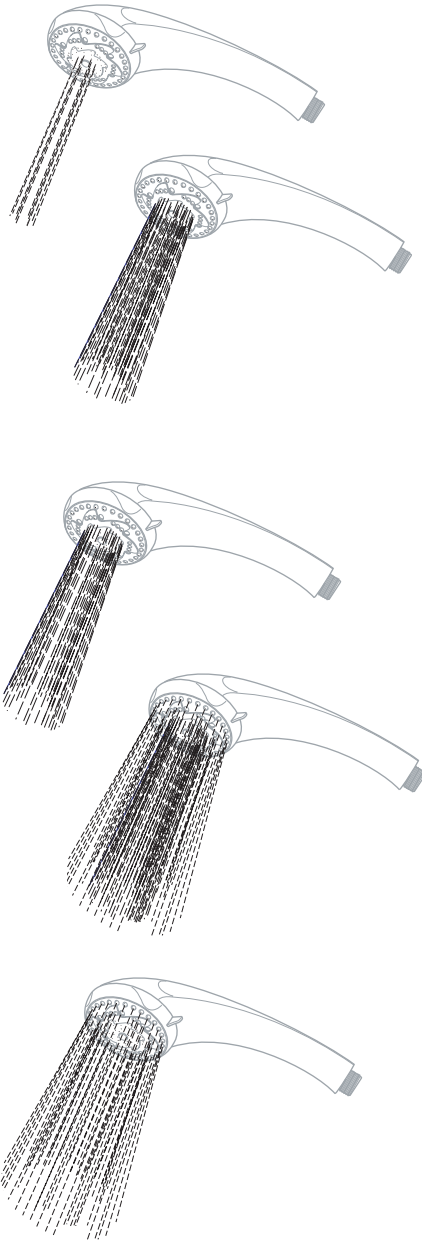

## ADJUSTING THE SHOWERHEAD

Five showerhead patterns are available (**fig.33**). Adjust the spray pattern by turning the bezel on the showerhead in either direction until the desired pattern is obtained.

## CLEANING

### WARNING!

**DO NOT use 'powerful' abrasive or solvent cleaning fluids when cleaning the shower as they may damage the plastic fittings.**

IT IS IMPORTANT TO KEEP THE SHOWERHEAD CLEAN TO MAINTAIN THE PERFORMANCE OF THE SHOWER. The hardness of the water will determine the frequency of cleaning. For example, if the shower is used every day in a very hard water area, it may be necessary to clean the showerhead on a weekly basis.

### Showerhead removal

There is no need to remove the showerhead from the hose.

Using the removal tool supplied (**fig.34**), locate the raised 'bosses' into the recesses in the sprayplate. Hold in firmly and twist anti-clockwise (**fig.35**). This movement may turn the cartridge assembly as well until it reaches a 'stop'. Hold the cartridge firmly and continue to twist anti-clockwise. Having loosened the sprayplate, it can be unscrewed and removed completely.

Clean the sprayplate with a suitable brush or preferably leave it to soak overnight in a mild proprietary descaler. Make sure all traces of scale are removed and thoroughly rinse in clean water afterwards.

Before replacing the sprayplate, turn the temperature control fully anti-clockwise to the maximum temperature setting.

Turn the flow control anti-clockwise. This operation will flush out any loose scale deposits in the unit and showerhead. Stop after about thirty seconds.

Refit the sprayplate by screwing clockwise. Use the tool to screw the sprayplate tight.

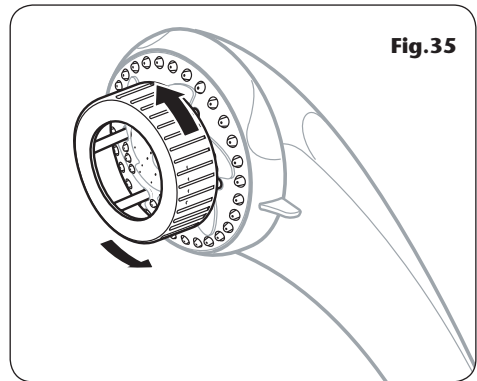
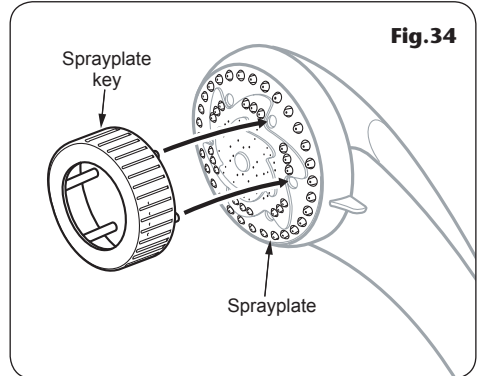

SPARE PARTS

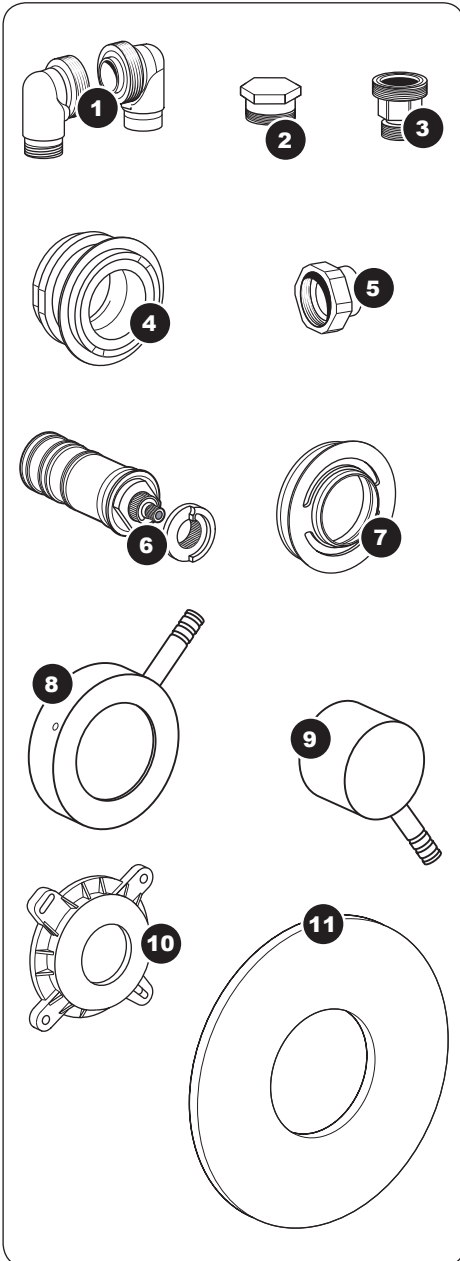

Ref.	Description	Part No.
1	Elbow	83307730
2	Plug	83307810
3	Outlet connector	83307740
4	Slide valve	83307780
5	Connection	83307840
6	Thermostatic cartridge w/ temperature stop	83307770
7	Upper flange	83307790
8	Flow control	83308150
9	Temperature control w/ cover trim	83308160
10	Fixing bracket	83307710
11	Trim plate	83307750
-	Flow limiter	83307760

SPARE PARTS

Ref.	Description	Part No.
12	Brackets (pair)	22010430
13	Trims (pair) - chrome	22010740
14	Riser rail	22010750
15	Showerhead holder - chrome	22010730
16	Soap dish & hose retainer	22010470
17	Showerhead	22011110
18	Shower hose	28100000
-	Bulkhead fitting	85500230
-	Nutted long thread connector	7032915

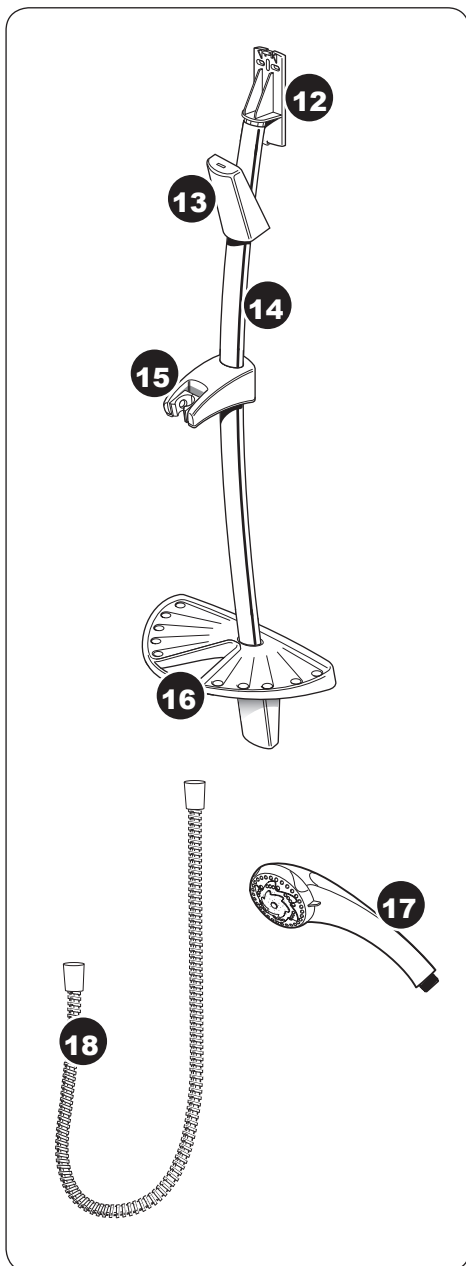

## FAULT FINDING

The following can be carried out by a competent person

<i>Problem/Symptom</i>	<i>Cause</i>	<i>Action/Cure</i>
<b>1</b> Water too hot.	<b>1.1</b> Temperature control incorrectly commissioned.	<b>1.1.1</b> Refer to 'commissioning' section.
	<b>1.2</b> Not enough cold water flowing through shower.	<b>1.2.1</b> Turn temperature control anti-clockwise.
	<b>1.3</b> Increase in the ambient cold water temperature.	<b>1.3.1</b> Turn temperature control anti-clockwise.
	<b>1.4</b> Cold water supply blocked.	<b>1.4.1</b> Turn shower off and consult a competent plumber or contact Triton Customer Service.
	<b>1.5</b> High volume of cold water drawn off elsewhere.	<b>1.5.1</b> Reduce the simultaneous demand from the mains supply.
<b>2</b> Water too cold.	<b>2.1</b> Temperature control incorrectly commissioned.	<b>2.1.1</b> Refer to 'commissioning' section.
	<b>2.2</b> Not enough hot water flowing through shower.	<b>2.2.1</b> Turn the temperature control clockwise. (Override max. temperature stop if necessary).
	<b>2.3</b> Decrease in the ambient cold water temperature.	<b>2.3.1</b> Turn the temperature control clockwise. (Override the maximum temperature stop if necessary).
	<b>2.4</b> Insufficient hot water supplies from the heating system.	<b>2.4.1</b> Make sure heating appliance is set to maximum or has sufficient stored hot water.
	<b>2.4.2</b> Make sure heating appliance is igniting by trying a hot water tap elsewhere.	<b>2.5.1</b> Turn off shower and consult a competent plumber or contact Triton Customer Service.
	<b>2.5</b> Hot water supply blocked or restricted.	<b>2.6.1</b> Fit the supplied flow limiters in the inlet elbows (see 'instantaneous gas water heaters' on page 8).
<b>2.6</b> Flow limiter not fitted (HP systems only).		
<b>3</b> High water flow and/or poor performance on a mains fed system.	<b>3.1</b> Flow limiters not fitted.	<b>3.1.1</b> Fit the supplied flow limiters in the inlet elbows (see 'high pressure systems' on page 7).
<b>4</b> Water does not flow or shower pattern collapses when another outlet is turned on.	<b>4.1</b> Water supplies cut off.	<b>4.1.1</b> Check water elsewhere in house and if necessary contact local water company.
	<b>4.2</b> Shower unit blocked.	<b>4.2.1</b> Inspect the filters. Clean if necessary.
	<b>4.3</b> Blockage in pipework.	<b>4.3.1</b> Turn the shower off and consult a suitably competent plumber.
	<b>4.4</b> Showerhead blocked.	<b>4.4.1</b> Clean showerhead.
	<b>4.5</b> System not capable of supplying multiple outlets at the same time.	<b>4.5.1</b> Reduce the simultaneous demand. <b>4.5.2</b> Check stop or service valve is fully open. <b>4.5.3</b> Check if sufficient water pressure.



