

ASPIRANTE

FERVORE

***Thermostatic bar
mixer shower***



Installation and Operating Instructions



INSTALLERS PLEASE NOTE THESE INSTRUCTIONS ARE TO BE LEFT WITH THE USER

CONTENTS	Page
Introduction	1
Safety warnings	1
Main components	2
Site requirements	3
Typical suitable installations	4 – 5
Instantaneous water heater appliance capabilities	6
Preparing the mixer valve	6
Siting of the shower	6
Installation	7 – 8
Leak testing	8
Commissioning	8 – 9
Operating the shower	9
Cleaning the filters	9
Spare parts	10
Fault finding	11 – 12
Guarantee, service policy, etc.	rear cover

To check the product suitability for commercial and multiple installations, please contact Triton's specification

Telephone: 0870 067 3767

Facsimile: 0870 067 3334

E mail: technical@tritonshowers.co.uk

INTRODUCTION

This book contains all the necessary fitting and operating instructions for your Aspirante Fervore thermostatic bar mixer shower.

Please read the instructions carefully. Read through the whole of this book BEFORE beginning your installation.

The shower installation MUST be carried out by a suitably competent person and in sequence of this instruction book.

Care taken during the installation will provide a long and trouble free life from your shower.

For best performance within the specified running pressure range a minimum flow of eight litres per minute should be available to both inlets.

The mixer shower MUST NOT be subjected to water temperatures above 80°C.

This tap is suitable for high water pressures only and should be fitted in accordance with Water Regulations.

Pressure range — 0.5 bar to 5 bar

The mixer is suitable for fully modulating type combination boilers and multi-point hot water heaters. It is also suitable for thermal storage, unvented systems and pumped gravity systems.

IMPORTANT: Before installing with a gas instantaneous water heater, make sure it is capable of delivering hot water at a minimum switch-on flow rate of 3 litres per minute. At flow rates between 3 and 8 litres per minute, the appliance must be capable of raising the water temperature to a minimum of 52°C. Water temperature at the inlet to the mixer must remain relatively constant when flow rate adjustments are made (*refer to the water heater operating manual to confirm compatibility with this mixer shower*).

This mixer is supplied with an integral single check valve and integral filter in each inlet. Inlet connections are to 15mm ½" BSP female fittings (*not supplied*).

SAFETY WARNINGS

- a. Layout and sizing of pipework must be such that when other services are used, pressures at the shower control inlets do not fall below the recommended minimum.
- b. **DO NOT choose a position where the shower could become frozen.**
- c. DO NOT connect this mixer shower to any form of tap or fitting not recommended by the manufacturer.
- d. The showerhead MUST be regularly cleaned to remove scale and debris.
- e. Conveniently situated service valves in each inlet supply MUST be fitted as an independent method of isolating the shower should maintenance or servicing be necessary.
- f. If it is intended to operate the shower in areas of hard water (above 200 ppm temporary hardness), a scale inhibitor may have to be fitted. For advice on the Triton scale inhibitor, please contact Customer Service.
- g. DO NOT operate the shower outside the guidelines as laid out in '*site requirements*'.

Replacement parts can be ordered from Triton Customer Service. See '*spare parts*' for details and part numbers.

MAIN COMPONENTS

Fig.1

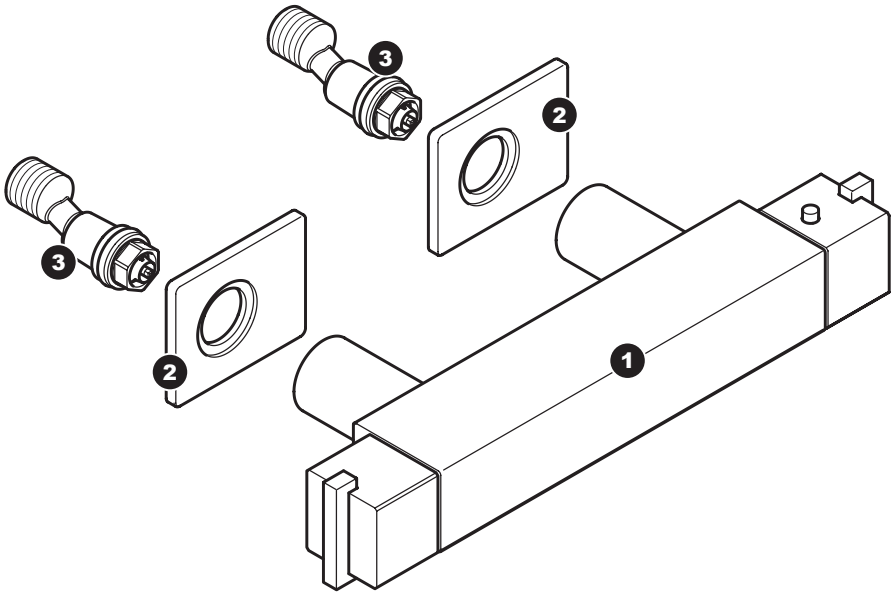

Ref Description

1. Fervore thermostatic bar mixer.
2. Cover trim (2 off)
3. Offset inlet connector (2 off).

SITE REQUIREMENTS

The installation must be in accordance with Water Regulations and Byelaws.

Running water pressure:

0.5 bar min. to 5.0 bar max.

Maximum static water pressure:

10 bar

DO NOT connect the mixer shower to a gravity hot supply and a mains cold supply (or vice versa).

For the best performance within the specified running pressure range a minimum flow of eight litres per minute should be available to both inlets.

While the mixer shower is operational (open outlet), inlet pressures must not be capable of exceeding 7 bar. For effective operation of the internal seals, the maximum static pressure must not be exceeded.

Note: On sites where the running pressure is above 5 bar, the use of a suitably sized pressure reducing valve fitted in the cold mains supply pipework can provide nominally equal pressures at the mixer shower.

The pipework should be installed such that the flow is not significantly affected by other taps and appliances being operated elsewhere on the premises.

Where thermal store systems and instantaneous gas water heaters are used, if excessive draw-offs take place the boiler may not be able to maintain an adequate output temperature. This could result in the shower temperature becoming noticeably cooler.

Water temperature requirements

Maximum hot water temperature = 80°C

Recommended maximum = 65°C

Minimum hot water temperature = 52°C

Maximum cold water temperature = 20°C

BS 6700 recommends that the temperature of stored water should never exceed 65°C.

A stored water temperature of 60°C is considered sufficient to meet all normal requirements and will minimise the effects of scale in hard water areas.

Temperature adjustment range

The mixed water temperature can be adjusted from cold through to a top limit which can be preset during installation. This is with full anti-scald protection throughout the range (35°C to 40°C) providing the hot water temperature at the inlet remains 10°C above the outlet temperature.

Note: Should there be a loss of flow to either incoming supply then water from the shower will stop or be reduced to a trickle until both supplies are restored.

Fig.2 (diagrammatic view – not to scale)

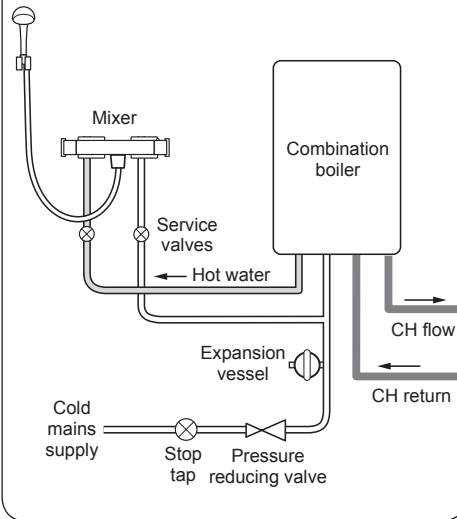

TYPICAL SUITABLE INSTALLATIONS

a) Instantaneous gas-heated systems, e.g. combination boilers (fig.2)

The shower control **MUST** be installed with a multipoint gas water heater or combination boiler of a fully modulating design (i.e. to maintain relatively stable hot water temperatures).

A drop tight pressure reducing valve **MUST** be fitted if the supply pressures exceed 5 bar running.

An expansion vessel (shown in **fig.2**) **MUST** be fitted, and regularly maintained, to prevent the shower mixer being damaged by excess pressures. This may already be installed within the boiler (check with manufacturer) and is in addition to the normally larger central heating expansion vessel.

The layout and sizing of pipework **MUST** be such that nominally equal inlet supply pressures are achieved and the effects of other draw-offs are minimised. The hot supply temperature **MUST** remain a minimum of 10°C hotter than the required blend temperature for optimum performance.

b) Unvented mains pressure systems (fig.3)

The shower control can be installed with an unvented, stored hot water cylinder.

For systems with no cold water take off after the appliance reducing valve, it will be necessary to fit an additional drop tight pressure reducing valve when the mains pressure is over 5 bar.

The drop tight pressure reducing valve must be set at the same value as the unvented package pressure reducing valve.

Note: An additional expansion vessel (**fig.3**) may be required if a second pressure reducing valve is installed. This does not apply to packages with a cold take off after the pressure reducing valve to the cylinder.

The layout and sizing of pipework **MUST** be such that nominally equal inlet supply pressures are achieved and the effects of other draw-offs are minimised.

Fig.3 (diagrammatic view – not to scale)

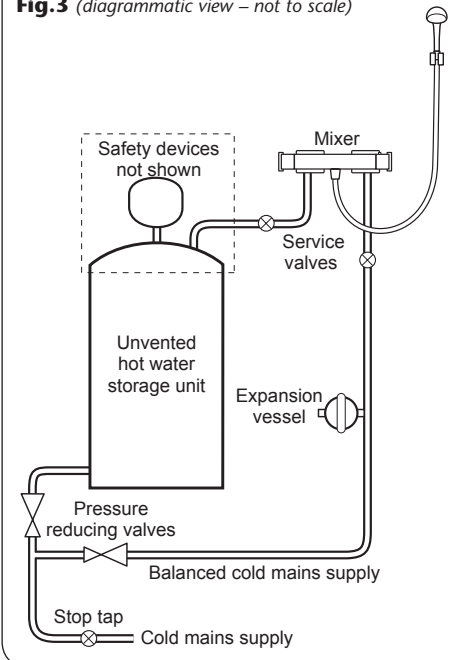

c) Mains pressurised thermal store systems (fig.4)

Packages of this type, fitted with a tempering valve (blender valve) can be used. A drop tight pressure reducing valve **MUST** be fitted if the supply pressures exceed 5 bar running.

An expansion vessel (shown in **fig.4**) **MUST** be fitted, and regularly maintained, to ensure the unit is not damaged by excess pressures. This may already be installed externally or internally within the thermal store (check with thermal store manufacturer).

d) Gravity fed systems (fig.5)

The shower control **MUST** be fed from a cold water cistern and hot water cylinder providing nominally equal pressures. There must be a minimum of 5 metre head of water. The minimum head distance is measured from the base of the cold water cistern to top of the showerhead.

e) Pumped gravity fed systems (fig.6)

The shower control **MUST** be fed from a cold water cistern and hot water cylinder providing nominally equal pressures.

The mixer unit may be used with a gravity fed system with a pump to boost pressures as shown.

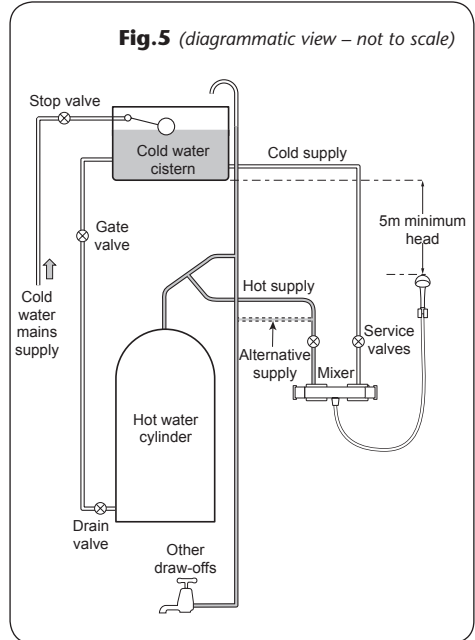
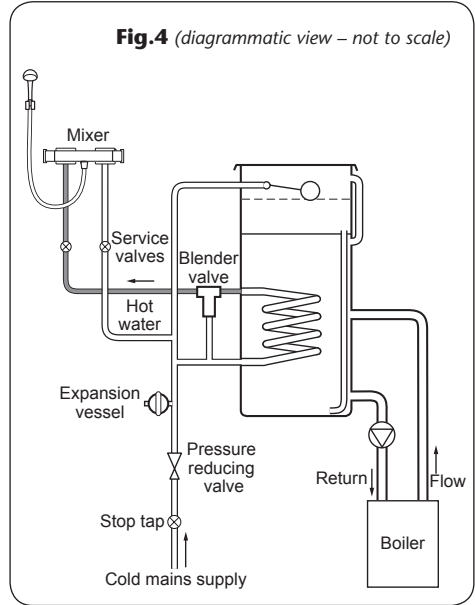

Fig.6 (diagrammatic view – not to scale)

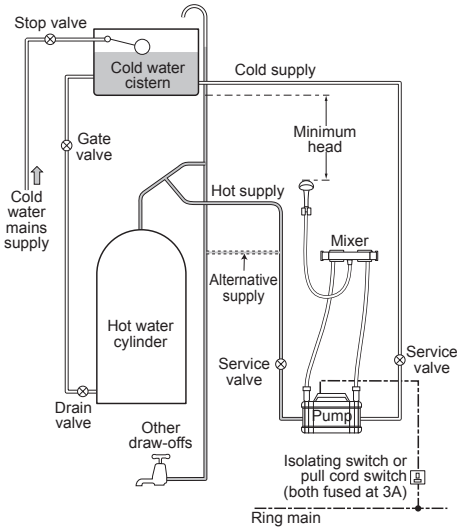
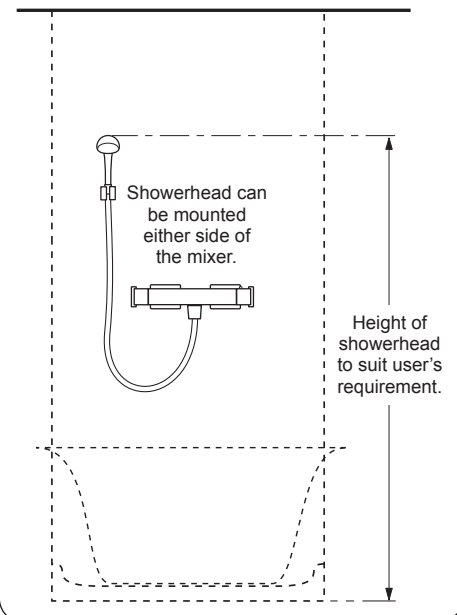

Fig.7 (diagrammatic view – not to scale)



INSTANTANEOUS WATER HEATERS APPLIANCE CAPABILITIES

In order to provide the best performance from the shower when connected to an instantaneous water heater, the appliance must be capable of raising the temperature of the incoming water to a minimum of 52°C (125°F) and delivering a flow rate of not less than eight litres per minute.

PREPARING THE MIXER VALVE

WARNING!

The shower must not be positioned where it will be subject to freezing conditions.

Check the contents to make sure all parts are present.

Before installing, make sure all the openings on the mixer unit are carefully covered to stop ingress of any debris, etc. while routing the shower pipework.

The shower valve is suitable for installation on a solid wall, a stud partition wall, dry lined wall or fixing to a laminate cubicle or panel.

The hot and cold water pipes should be securely attached within the wall or panel to support the valve and prevent movement after installation.

The hot water inlet has a red symbol next to the inlet and must be on the left-hand side.

SITING OF THE SHOWER

Refer to (fig.7) for correct siting of the shower.

Position the shower and showerhead on the wall so that all controls can be comfortably reached while using the shower. The showerhead can be positioned either side of the shower.

The unit must be positioned horizontally with the outlet port at the bottom.

INSTALLATION

Note: The outlet of the shower MUST NOT be connected to anything other than that recommended by Triton Plc.

DO NOT use jointing compounds on any pipe fittings for the installation.

DO NOT solder fittings near the mixer unit as heat can transfer along the pipes and can damage the seals and thermostatic components.

Note: Suitable service valves (complying with Water Regulations and Byelaws) MUST be fitted on the hot and cold water supplies to the shower as an independent means of isolating the water supplies should maintenance or servicing be necessary.

When connecting the pipework, avoid using tight 90° elbows. Swept or formed bends will give the best performance.

Offset fittings

The supply pipes can be routed either from the side, rising, rear or falling and must end in suitable ½" BSP female fittings (**fig.8**) to accept the offset connector.

The inlet centres on the shower valves are 150mm but with the offset fittings an additional 20mm adjustment is provided.

When installing into a stud partition or other hollow wall structures, the installer will need to consider building rear supports or other options. Such options are beyond the scope of this guide.

The hot and cold supply pipes must be anchored rigidly in order to support the valve and prevent movement after installation.

The pipe depth must be such that the face of the elbow is flush with the finished surface.

Flush out the pipework in accordance with Water Regulations and Byelaws.

Using PTFE thread tape, screw the supplied offset fittings into the female elbows (**fig.9**). Make sure the fittings are level and set at 150mm between centres.

Make good the wall, tiling, etc. up to the outlets.

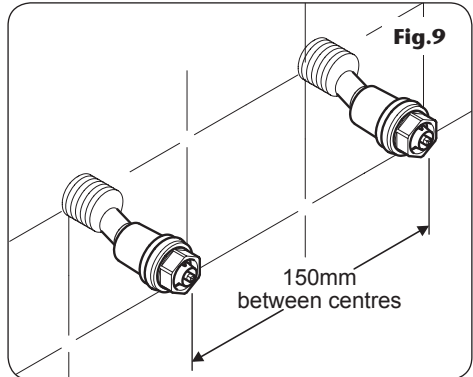
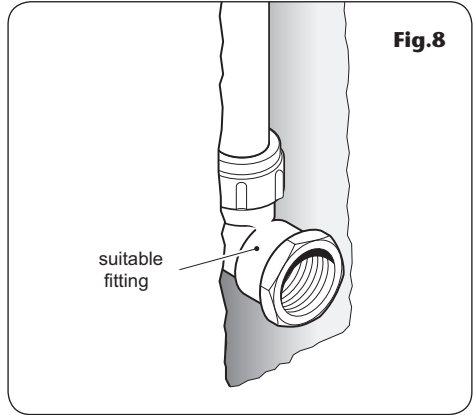

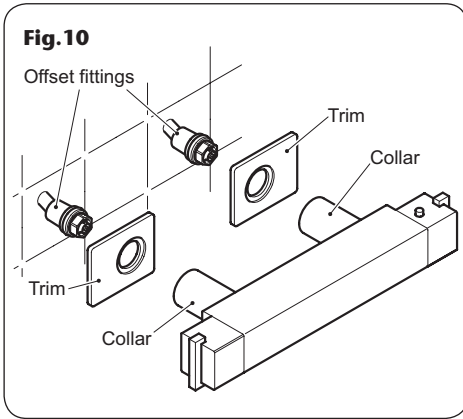

The collars will provide a limited degree of tolerance and the amount of exposed thread will depend on the accuracy of elbows set in the wall.

Apply a bead of silicon sealant to the back faces of the trims and slide the trims over the offset connectors. Offer the bar mixer to the offset fittings (**fig.10**). Check that the sealing washers are placed on the offset fittings, then slide the collars onto the fittings. Make sure the collars sit correctly in the recess in the trims. Using a suitable Allen key, secure the mixer to the wall by tightening the grub screws in the base of the collars (**fig.11**).

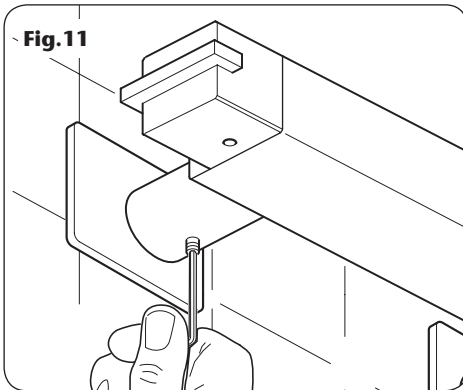

Fitting the flexible hose

Fit the flexible hose to the outlet on the underside of the mixer unit, making sure that the sealing washers supplied are inserted into each end of the hose cone (**fig.12**).

LEAK TESTING

Fit the hose to the outlet and direct it to waste. Open the supplies and test for leaks in the valve connections. Remedy any leaks if necessary.

COMMISSIONING

Make sure that both the hot and cold water supplies are fully open and at (or near to) their design temperature and pressures, and are within the requirements as stated.

Check the temperature knob (right-hand side) is rotated fully anti-clockwise (press the override button to achieve maximum temperature setting).

Make sure the showerhead is directed to waste.

Start the water flow by turning the flow control (left-hand side) anti-clockwise.

Allow the shower to run at the maximum temperature setting until the water temperature has stabilised. Using the temperature control knob, rotate until your desired maximum showering temperature is reached.

The mixer valve contains a maximum temperature override button set at 38°C.

The mixer valve is factory set to provide a maximum outlet temperature of 38°C but this

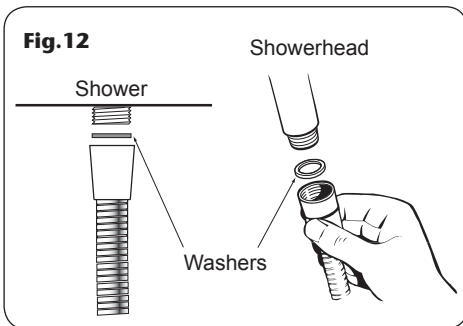

should be checked on site to check that the setting has not been altered and also to ensure user safety.

Adjusting the maximum temperature override setting

Remove the temperature control knob by unscrewing the retaining grub screw (fig.13).

Turn the flow control knob fully anti-clockwise. With a steady flow running, adjust the temperature valve spindle (fig.14) until the temperature is about 38°C (turn right for cold and left for warm).

When you are satisfied with the temperature turn the flow control off. Refit the temperature control knob, checking that the temperature stop is at the 12 o'clock position. Carefully rotate the temperature control to allow access to the locking grub screw and, with a suitable Allen key, tighten the screw.

OPERATING THE SHOWER

To start the shower, rotate the On/Off flow handle (left-hand side) fully anti-clockwise for maximum flow.

To stop the water flow, rotate the On/Off flow handle fully clockwise.

To adjust the water temperature, rotate the temperature control (right-hand side) – clockwise for a cooler shower or anti-clockwise for a hotter shower (fig.15).

To overcome the maximum temperature stop, depress the button (fig.16).

CAUTION: Exposed metal surfaces may become hot during use.

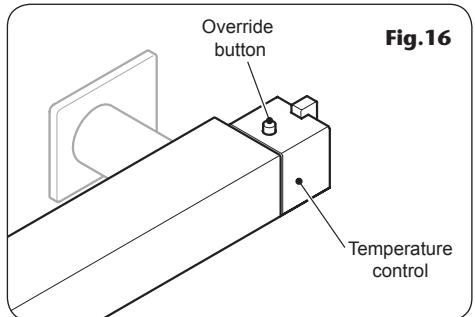
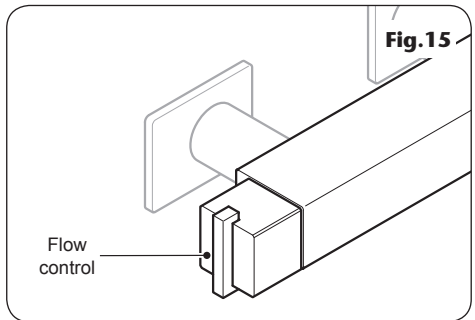
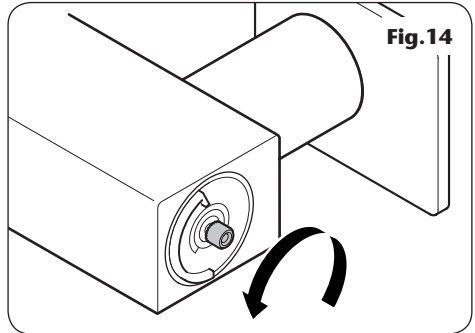
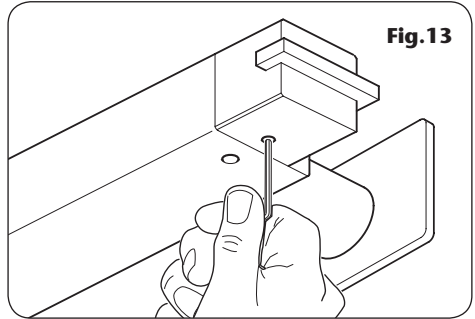

SPARE PARTS

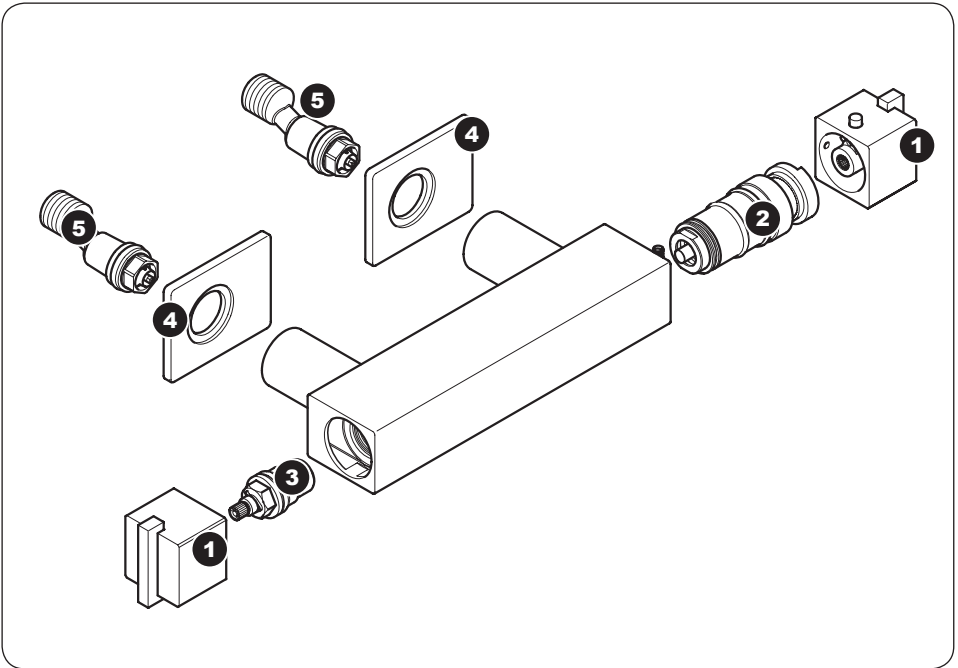

Ref.	Description	Part No.
1.	Control knobs (pair)	83309360
2.	Thermostatic cartridge	83309300
3.	¼ turn cartridge	83309260
4.	Trim pack (pair)	83309390
5.	Offset inlet connector	83309380

FAULT FINDING

The following can be carried out by a competent person

Problem/Symptom	Cause	Action/Cure
1 Water too hot.	1.1 Temperature control incorrectly commissioned.	1.1.1 Refer to commissioning section.
	1.2 Not enough cold water flowing through shower.	1.2.1 Turn temperature control clockwise.
	1.3 Increase in the ambient cold water temperature.	1.3.1 Turn temperature control clockwise.
	1.4 Cold water supply blocked.	1.4.1 Turn off shower and consult a competent plumber or contact Triton Customer Service.
	1.5 High volume of cold water drawn off elsewhere.	1.5.1 Reduce the simultaneous demand from the supply.
2 Water too cold.	2.1 Temperature control incorrectly commissioned.	2.1.1 Refer to commissioning section.
	2.2 Not enough hot water flowing through shower.	2.2.1 Turn the temperature control anti-clockwise.
	2.3 Decrease in the ambient cold water temperature.	2.3.1 Turn the temperature control anti-clockwise.
	2.4 Insufficient hot water supplies from the heating system.	2.4.1 Make sure heating appliance is set to maximum or has sufficient stored hot water. 2.4.2 Make sure heating appliance is igniting by trying a hot water tap elsewhere.
	2.5 Hot water supply blocked or restricted.	2.5.1 Turn off shower and consult a competent plumber or contact Triton Customer Service.

FAULT FINDING

The following is recommended for a professional qualified installer only

Problem/Symptom	Cause	Action/Cure
3 Water does not flow or shower pattern collapses when another outlet is turned on.	3.1 Water supplies cut off.	3.1.1 Check water elsewhere in house and if necessary contact local water company.
	3.2 Shower unit blocked.	3.2.1 Inspect the inlet filters. Clean if necessary.
	3.3 Blockage in pipework.	3.3.1 Turn off the shower and consult a suitably competent plumber.
	3.4 Showerhead blocked.	3.4.1 Clean showerhead.
	3.5 System not capable of supplying multiple outlets at the same time.	3.5.1 Reduce the simultaneous demand. 3.5.2 Make sure stop/service valves are fully open. 3.5.3 Check if sufficient water pressure.
4 Water too cold.	4.1 Running pressure in excess of maximum recommended.	4.1.1 Fit a pressure reducing valve.
5 Shower controls noisy while in use.	5.1 Running pressure in excess of maximum recommended.	5.1.1 Fit a pressure reducing valve.
6 Shower will not shut off.	6.1 Flow control washer worn.	6.1.1 Renew flow control washer.



Service Policy

In the event of a complaint occurring, the following procedure should be followed:

- 1 Telephone Customer Service on 0870 067 3333 (0845 762 6591 in Scotland and in Northern Ireland), having available the model number and power rating of the product, together with the date of purchase.
- 2 Triton Customer Service will be able to confirm whether the fault can be rectified by either the provision of a replacement part or a site visit from a qualified Triton service engineer.
- 3 If a service call is required the unit must be fully installed for the call to be booked and the date confirmed. In order to speed up your request, please have your postcode available when booking a service call.
- 4 It is essential that you or an appointed representative (who must be a person of 18 years of age or more) is present during the service engineer's visit and receipt of purchase is shown.
- 5 A charge will be made in the event of an aborted service call by you but not by us, or where a call under the terms of guarantee has been booked and the failure is not product related (i.e. scaling and furring, incorrect water pressure).
- 6 If the product is no longer covered by the guarantee, a charge will be made for the site visit and for any parts supplied.
- 7 Service charges are based on the account being settled when work is complete, the engineer will then request payment for the invoice. If this is not made to the service engineer or settled within ten working days, an administration charge will be added.

Replacement Parts Policy

Availability: It is the policy of Triton to maintain availability of parts for the current range of products for supply after the guarantee has expired. Stocks of spare parts will be maintained for the duration of the product's manufacture and for a period of five years thereafter.

In the event of a spare part not being available a substitute part will be supplied.

Payment: The following payment methods can be used to obtain spare parts:

- 1 By post, pre-payment of pro forma invoice by cheque or money order.
- 2 By telephone, quoting credit card (MasterCard or Visa) details.
- 3 By website order, www.tritonshowers.co.uk

Triton Showers
Triton Road
Nuneaton
Warwickshire CV11 4NR

Triton is a division of Norcros Group (Holdings) Limited

TRITON STANDARD GUARANTEE

Triton guarantee this product against all mechanical defects arising from faulty workmanship or materials for a period of five years for domestic use only, from the date of purchase, provided that it has been installed by a competent person in full accordance with the fitting instructions.

Any part found to be defective during this guarantee period we undertake to repair or replace at our option without charge so long as it has been properly maintained and operated in accordance with the operating instructions, and has not been subject to misuse or damage.

This product must not be taken apart, modified or repaired except by a person authorised by Triton. This guarantee applies only to products installed within the United Kingdom and does not apply to products used commercially. This guarantee does not affect your statutory rights.

What is not covered:

- 1 Breakdown due to: *a*) use other than domestic use by you or your resident family; *b*) wilful act or neglect; *c*) any malfunction resulting from the incorrect use or quality of water or incorrect setting of controls; *d*) faulty installation.
- 2 Repair costs for damage caused by foreign objects or substances.
- 3 Total loss of the product due to non-availability of parts.
- 4 Compensation for loss of use of the product or consequential loss of any kind.
- 5 Call out charges where no fault has been found with the appliance.
- 6 The cost of repair or replacement of showerheads, hoses, riser rails and/or wall brackets or any other accessories installed at the same time.
- 7 The cost of routine maintenance, adjustments, overhaul modifications or loss or damage arising therefrom, including the cost of repairing damage, breakdown, malfunction caused by corrosion, furring, pipe scaling, limescale, system debris or frost.

Customer Service: ☎ 0870 067 3333

**Scottish and Northern Ireland
Customer Service:** ☎ 0845 762 6591

Trade Installer Hotline: ☎ 0870 067 3767
Fax: 0870 067 3334

www.tritonshowers.co.uk

E mail: technical@tritonshowers.co.uk