

**TRITON**

**Enrich  
electric shower**

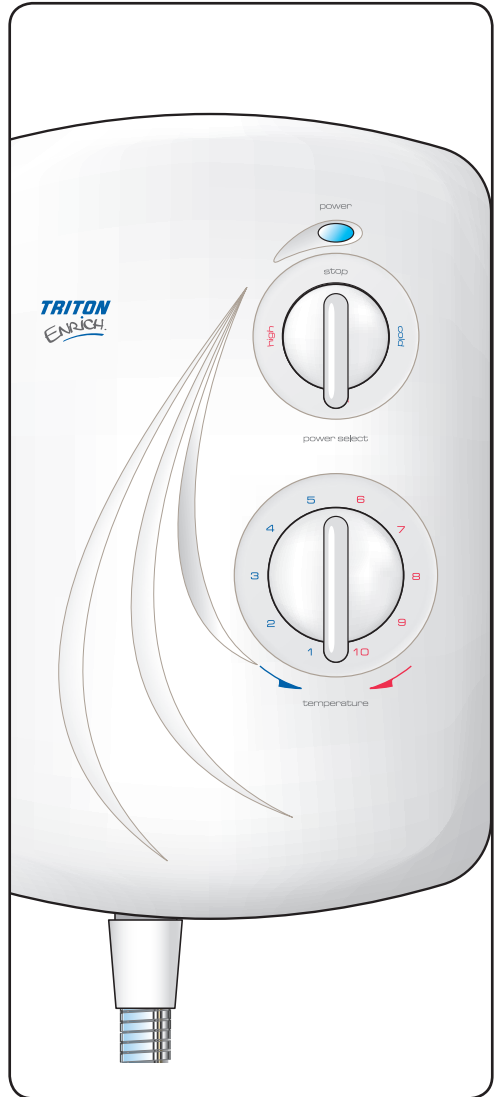

**Installation and  
operating  
instructions**

INSTALLERS PLEASE NOTE THESE INSTRUCTIONS ARE TO BE LEFT WITH THE USER

<b>CONTENTS</b>	<b>Page</b>
Important safety information .....	1
Introduction .....	2
Specifications.....	2
Advice to users .....	2
Main components .....	3
Electrical requirements.....	4 - 5
Water requirements .....	6
Siting of the shower .....	7
Fitting the shower to the wall.....	8 - 9
Plumbing connections .....	10
Electrical connections .....	11
Replacing the cover .....	12
Commissioning.....	13
Operating the shower.....	14 - 15
Operating functions.....	16
Instructions for installers and service engineers only .....	17
Spare parts .....	18
Fault finding .....	19 - 20
Guarantee, service policy, etc. ....	rear cover

To check the product suitability for commercial and multiple installations, please contact Triton's specification advisory service before installation.

Telephone: 0844 980 0730

Facsimile: 0844 980 0744

E mail: [technical@tritonshowers.co.uk](mailto:technical@tritonshowers.co.uk)

**PLEASE READ THIS IMPORTANT SAFETY INFORMATION**

- ◆ Products manufactured by Triton are safe and without risk provided they are installed, used and maintained in good working order in accordance with our instructions and recommendations.
- ◆ **WARNING: DO NOT** operate shower if frozen, or suspected of being frozen. It must thaw out before using.
- ◆ **DO NOT** operate the unit if the showerhead or spray hose becomes damaged.
- ◆ **DO NOT** restrict flow out of shower by placing showerhead in direct contact with your body.
- ◆ **DO NOT** operate the shower if water ceases to flow during use or if water has entered inside the unit because of an incorrectly fitted cover.
- ◆ **WARNING: If restarting the shower immediately after stopping, be aware that a slug of hot water will be expelled for the first few seconds.**

**1 GENERAL**

- 1.1** Isolate the electrical and water supplies before removing the cover.
- 1.2** Read all of these instructions and retain them for later use.
- 1.3** DO NOT take risks with plumbing or electrical equipment.
- 1.4** Isolate electrical and water supplies before proceeding with the installation.
- 1.5** The unit must be mounted onto the finished wall surface (on top of the tiles). Do not tile up to unit after fixing to wall.
- 1.6** Contact Customer Service (*see back page*), if any of the following occur:
  - a)** If it is intended to operate the shower at pressures above the maximum or below the minimum stated.
  - b)** If the unit shows a distinct change in performance.
  - c)** If the shower is frozen.
- 1.7** If it is intended to operate the shower in areas of hard water (above 200 ppm temporary hardness), a scale inhibitor may have to be fitted. For advice on the Triton Scale Inhibitor, contact Triton Customer Service.
- 1.8** The showerhead must be cleaned regularly with descalent to remove scale and debris, otherwise restrictions to the flow on the outlet of the unit will result in higher temperatures and could also cause the Pressure Relief Device in the unit to operate.
- 1.9** This product is not suitable for mounting into steam rooms or steam cubicles.

**2 PLUMBING**

- 2.1** The plumbing installation must comply with Water Regulations, Building Regulations or any particular regulations as specified by Local Water Company or Water Undertakers and should be in accordance with BS 6700.
- 2.2** The supply pipe must be flushed to clear debris before connecting to the shower unit.
- 2.3** DO NOT solder pipes or fittings within

300mm of the shower unit, as heat can transfer along the pipework and damage components.

- 2.4** DO NOT fit any form of outlet flow control as the outlet acts as a vent for the heater can.
- 2.5** DO NOT use excessive force when making connections to the flexible hose or showerhead, finger tight is sufficient.
- 2.6** All plumbing connections must be completed before making the electrical connections.

**3 ELECTRICAL**

- 3.1** The installation must comply with BS 7671 'Requirements for electrical installations' (IEE wiring regulations), building regulations or any particular regulations as specified by the local Electrical Supply Company.
- 3.2** This appliance MUST be earthed.
- 3.3** In accordance with 'The Plugs and Sockets etc. (Safety) Regulations 1994', this appliance is intended to be permanently connected to the fixed wiring of the electrical mains system.
- 3.4** Make sure all electrical connections are tight to prevent overheating.
- 3.5** Fuses do not give personal protection against electric shock.
- 3.6** A 30mA residual current device (RCD) MUST be installed in all UK electric and pumped shower circuits. This may be part of the consumer unit or a separate unit.
- 3.7** Switch off immediately at isolating switch if water ceases to flow during use.
- 3.8** Other electrical equipment i.e. extractor fans, pumps must not be connected to the circuits within the unit.
- 3.9** Switch off at isolating switch when not in use. This is a safety procedure recommended with all electrical appliances.
- 3.10** As with all electrical appliances it is recommended to have the shower and installation checked at least every two years by a competent electrician to ensure there is no deterioration due to age and usage.

### INTRODUCTION

This book contains all the necessary fitting and operating instructions for your Triton electric shower. Please read them carefully.

The shower installation must be carried out by a suitably qualified person and in the sequence of this instruction book.

Care taken during the installation will provide a long, trouble-free life from your shower.

### SPECIFICATIONS

#### Electrical

Nominal power rating at 240V	Nominal power rating at 230V
8.5kW – (40A MCB rating)	7.8kW – (40A MCB rating)

#### Water

Inlet connection – 15 mm diameter.

Outlet connection – ½" BSP male thread.

#### Entry Points

Water – top, bottom, back, left or right.

Cable – top, bottom, back, left or right.

#### Materials

Backplate, cover, controls, showerhead – ABS.

Sprayplate – Acetal.

Elements – Minerally insulated corrosion resistant metal sheathing.

#### Dimensions

Height – 305 mm

Width – 210 mm

Depth – 110 mm

#### Standards and Approvals

Waterproof rating IPX4.

Complies with the requirements of current British and European safety standards for household and similar electrical appliances.

Complies with requirements of the British Electrotechnical Approvals Board (BEAB).

Meets with Compliance with European Community Directives (CE).

### ADVICE TO USERS

The following points will help you understand how the shower operates:

- a.** The electric heating elements operate at a constant rate at your chosen power setting. It is the rate of the water passing through the heater unit which determines the shower temperature at any given setting (the slower the flow the hotter the water becomes, and the faster the flow the cooler the water).
- b.** During winter, mains water supply will be cooler than in summer. Therefore the temperature of the shower will vary between seasons on any one setting of the temperature control, e.g. if you have chosen setting number 6 as your preferred shower temperature in the summer, you will have to increase that number during winter by adjusting the temperature control clockwise (which in effect slows the water flow).
- c.** The stabiliser valve minimises variations in shower temperature during mains water pressure changes. If changes in shower temperature are experienced during normal use, it will most likely be caused by the water pressure falling near to or below the minimum level. The drop in pressure may be due to water being drawn off at other points in the house whilst the shower is in use. If pressure drops appreciably below the minimum, the heating elements will automatically cut out.

If ever the water becomes too hot and you cannot obtain cooler water, first check that the sprayplate in the showerhead has not become blocked.

DO NOT place items such as soap or shampoo bottles on top of the unit. Liquid could seep through the joint between the cover and backplate, and possibly damage the sealing rubber.

Replacement parts can be ordered from Customer Service. See 'spare parts' for details and part numbers.

## MAIN COMPONENTS

### Inside unit (fig.1)

1. Top cable/pipe entry
2. Wall screw fixings
3. Cover screw fixings
4. Thermal safety cut-out (main)
5. Power selector assembly
6. Power neon
7. Can and element assembly
8. Pressure switch assembly
9. Stabilising valve
10. Terminal block
11. Earth connection
12. Solenoid valve
13. Water inlet
14. Outlet temperature limiter
15. Pressure relief device (PRD)
16. Trimplate
17. Shower outlet
18. Cover assembly

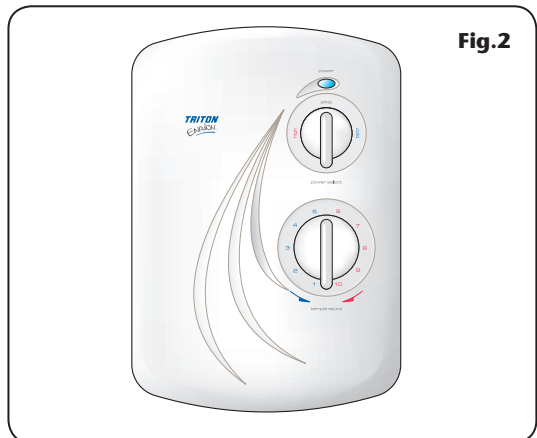
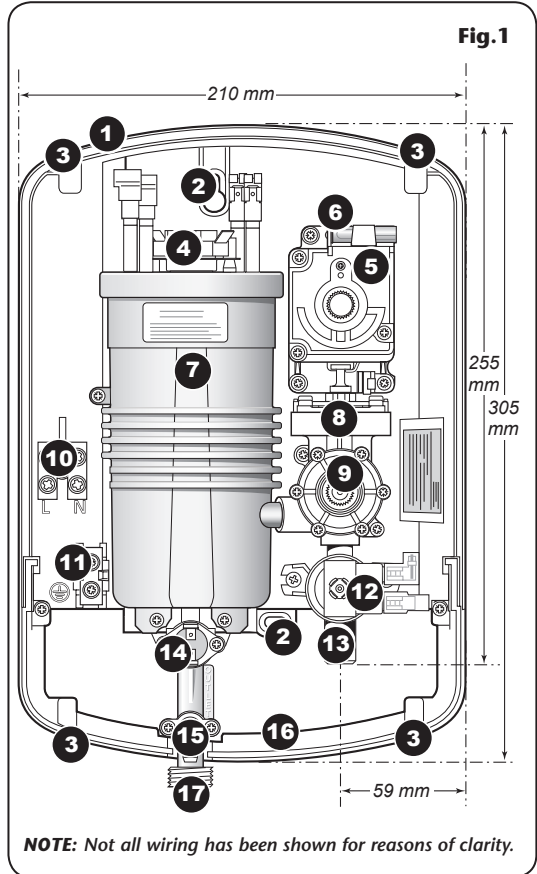

## ELECTRICAL REQUIREMENTS

**WARNING!**  
**THIS APPLIANCE MUST BE EARTHED**

The installation, supply cable and circuit protection must conform with BS 7671 (IEE wiring regulations) and be sufficient for the amperage required.

The following notes are for guidance only:

- 1** The shower must only be connected to a 230-240V ac supply. If you are installing a shower with a kilowatt rating above 9kW, it is advisable to contact the local electricity supply company.
- 1.1** The electrical rating of the shower is shown on the rating label (**Fig.3**) within the unit.
- 2** Before making any sort of electrical connection within the installation make sure that no terminal is live. If in any doubt, switch off the whole installation at the mains supply and remove the correct fuse.
- 3** The shower must be connected to its own independent electrical circuit. IT MUST NOT be connected to a ring main, spur, socket outlet, lighting circuit or cooker circuit.
- 3.1** The electrical supply must be adequate for the loading of the unit and existing circuits.
- 4** Check your consumer unit (main fuse box) has a main switch rating of 80A or above and that it has a spare fuse way which will take the fuse or Miniature Circuit Breaker (MCB) necessary for the shower (**Fig.4**).
- 4.1** If your consumer unit has a rating below 80A or if there is no spare fuse way, then the installation will not be straightforward and may require a new consumer unit serving the house or just the shower.
- 4.2** You will need to contact the local electricity company. They will check the supply and carry out what is necessary.
- 5** For close circuit protection DO NOT use a rewireable fuse. Instead use a suitably rated Miniature Circuit Breaker (MCB) or cartridge fuse (**see Table A**).

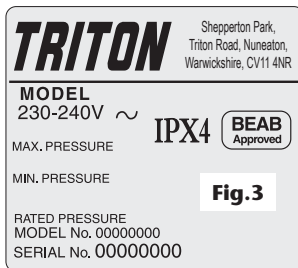

**Fig.4** Schematic of installation circuit

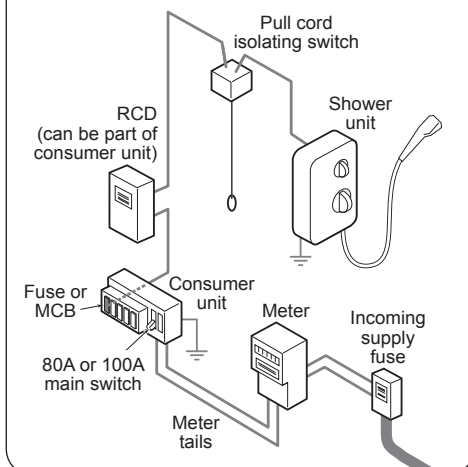

**Table A**

CIRCUIT PROTECTION		
unit rating	MCB	cartridge fuse
7.0kW	30/32A	30A
7.5kW	32A	35A
8.0kW	40A	35A
8.5kW	40A	45A
9.0kW	40A	45A
9.5kW	40/45A	45A
10.5kW	45A	45A

- 5.1** A 30mA residual current device (RCD) must be installed in all UK electric and pumped shower circuits. This may be part of the consumer unit or a separate unit.
- 6** A 45 amp double pole isolating switch with a minimum contact gap of 3 mm in both poles must be incorporated in the circuit.
- 6.1** It must have a mechanical indicator showing when the switch is in the OFF position, and the wiring must be connected to the switch without the use of a plug or socket outlet.
- 6.2** The switch must be accessible and clearly identifiable, but out of reach of a person using a fixed bath or shower, except for the cord of a cord operated switch, and should be placed so that it is not possible to touch the switch body while standing in a bath or shower cubicle. It should be readily accessible to switch off after using the shower.
- 7** Where shower cubicles are located in any rooms other than bathrooms, all socket outlets in those rooms must be protected by a 30mA RCD.
- 8** The current carrying capacity of the cable must be at least that of the shower circuit protection (**see Table B**).
- 8.1** To obtain full advantage of the power provided by the shower, use the shortest cable route possible from the consumer unit to the shower.
- 8.2** It is also necessary to satisfy the disconnection time and thermal constraints which means that for any given combination of current demand, voltage drop and cable size, there is a maximum permissible circuit length.
- 9** The shower circuit should be separated from other circuits by at least twice the diameter of the cable or conduit.
- 9.1** The current rating will be reduced if the cabling is bunched with others, surrounded by thermal loft or wall insulation or placed in areas where the ambient temperature is above 30°C. Under these conditions, derating factors apply and it is necessary to select a larger cable size.

- 9.2** In the majority of installations, the cable will unavoidably be placed in one or more of the above conditions. This being so, it is strongly recommended to use a minimum of 10mm cabling throughout the shower installation.
- 9.3** In any event, it is essential that individual site conditions are assessed by a competent electrician in order to determine the correct cable size and permissible circuit length.

**Table B**

**Twin and earth PVC insulated cable  
Current carrying capacity**

Installed in an insulated wall	In conduit trunking	Clipped direct or buried in a non-insulated wall
6 mm <sup>2</sup> 35A	6 mm <sup>2</sup> 38A	6 mm <sup>2</sup> 47A
10 mm <sup>2</sup> 47A	10 mm <sup>2</sup> 52A	10 mm <sup>2</sup> 64A
16 mm <sup>2</sup> 63A	16 mm <sup>2</sup> 69A	16 mm <sup>2</sup> 85A

**Note:** Cable selection is dependent on derating factors

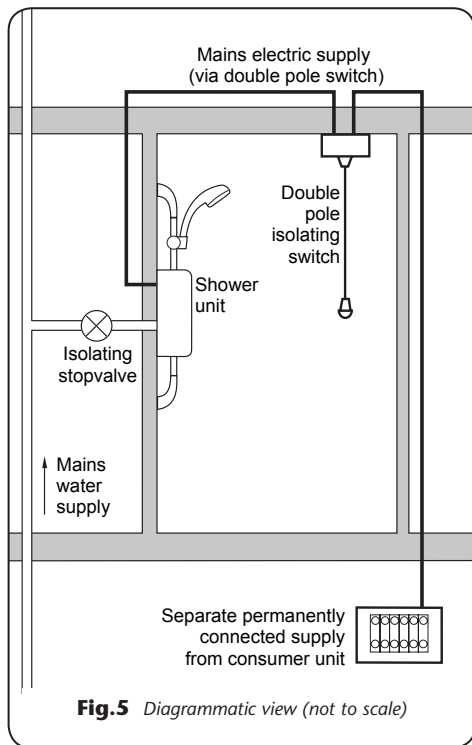

**Fig.5** Diagrammatic view (not to scale)

## WATER REQUIREMENTS

### WARNING!

**The shower must not be positioned where it will be subjected to freezing conditions.**

The installation must be in accordance with Water Regulations and Bylaws.

To guarantee activating the heating elements, the shower must be connected to a mains water supply with a minimum running pressure of 100kPa (1.0 bar) at a minimum flow rate of eight litres per minute for the 8.5kW rated model, and nine litres per minute for the 9.5kW rated model.

For all models the maximum static pressure must not exceed 1000kPa (10 bar).

**Note:** If the stated flow rates are not available, it may not be possible to achieve the best performance from the unit throughout the year.

During periods of high ambient temperatures it may be necessary to select a low power setting to achieve your preferred shower temperature.

The water supply can be taken from a cold water storage cistern provided there is a minimum head of ten metres above the showerhead. It must be an independent supply to the shower only.

If it is intended to operate the shower at pressures above the maximum or below the minimum stated, contact Customer Service for advice.

**Fig.5** shows a typical system layout.

**DO NOT use jointing compounds on any pipe fittings for the installation.**

## SITING OF THE SHOWER

**IMPORTANT:** If installing onto a tiled wall always mount the unit on the surface of the tiles. NEVER tile up to the unit.

Refer to **fig.6** for correct siting of shower.

Position the unit where it will NOT be in direct contact with water from the showerhead. Position the shower unit vertically.

Leave enough room between the ceiling and the shower to allow access to the cover top screws.

**Note:** Water Regulations require the showerhead be 'constrained by a fixed or sliding attachment so that it can only discharge water at a point not less than 25mm above the spill-over level of the relevant bath, shower tray or other fixed appliance'. The use of the supplied retaining ring/gel hanger will in most cases meet this requirement, but if the showerhead can be placed within a bath, basin or shower tray, then a double check valve, or similar, must be fitted in the supply pipework to prevent back-flow.

### Pressure relief safety device

A pressure relief device (PRD) is designed into the shower unit which complies with European standards. The PRD provides a level of appliance protection should an excessive build up of pressure occur within the shower.

DO NOT operate the shower with a damaged or kinked shower hose, or a blocked showerhead which can cause the PRD to operate.

When commissioning, the showerhead must be removed from the flexible hose, while at the same time the temperature control must be at the minimum flow position. Failure to follow this procedure may also cause the PRD to operate.

Make sure the shower is positioned over a bath or shower tray because if the PRD operates, then water will eject from the bottom of the unit.

Should this happen, turn off the electricity and water supplies to the shower at the isolating switch and stopvalve. Contact Customer Service for advice on replacing the PRD.

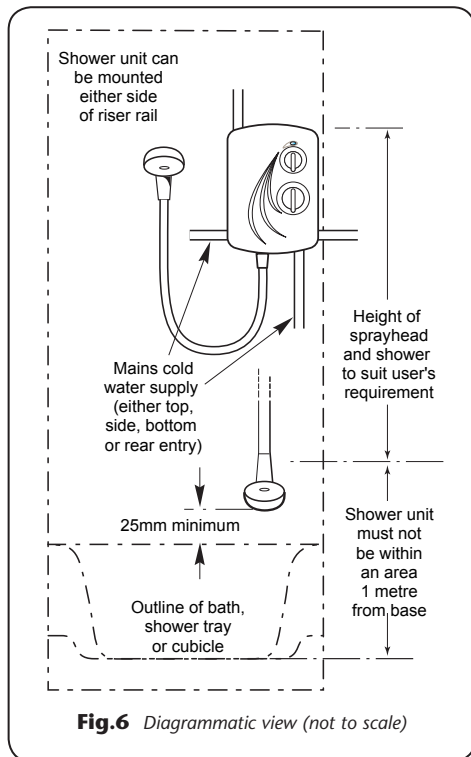

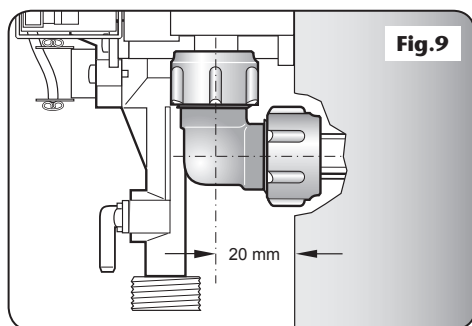
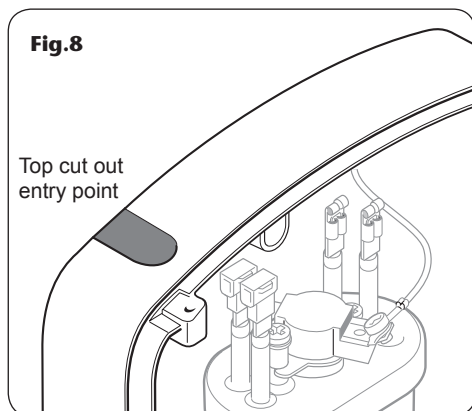
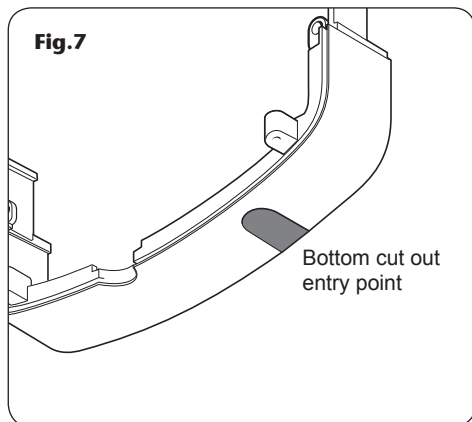

## FITTING THE SHOWER TO THE WALL

### WARNING!

**Check there are no hidden cables or pipes before drilling holes for wall plugs. Use great care when using power tools near water. The use of a residual current device (RCD) is recommended.**

**Note:** The control knobs are an integral part of the cover – DO NOT attempt to remove them. Lift the cover from the backplate and remove the trimplate..

Entry positions for the mains water and electric cable are from the top, bottom, either side or from the back.

**Note:** Deviations from the designated entry points will invalidate product approvals.

If a bottom entry has been chosen, the 'cut out' pipe entry on the bottom trimplate should be removed (**fig.7**).

If a top entry has been chosen, the 'cut out' pipe entry on the top of the backplate should be removed (**fig.8**).

If a side entry is required, the trimplate side will have to be cut. With the elbow compression fitted on the outlet, temporarily place the trimplate into position, then mark the pipe entry on the side of the trimplate. Carefully remove the appropriate area using a junior hacksaw.

**Please note: NONE of the 'cut outs' are designed to 'snap out'. DO NOT remove using pliers as the backplate or lower trimplate could be damaged.**

**A junior hacksaw or suitable knife should be used and any rough edges removed.**

**Damage to the backplate or lower trimplate will invalidate product specifications and warranty.**

If installing a feed pipe from the back or bottom, the centre of the inlet valve to the wall surface is 20mm (**fig.9**).

**Note:** If entry is from the back, the nut of the compression fitting will be partially behind the surface of the wall. This area **MUST** be left clear when plastering over the pipework in order to make the nut accessible for future adjustments.

After choosing the site for the shower, use the backplate as a template and mark the two fixing holes (**fig.10**).

Drill and plug the wall.

*(An appropriate drill bit should be used. If the wall is plasterboard or a soft building block, appropriate wall plugs and screws should be fitted).*

Screw the top fixing screw into position leaving the base of the screw head protruding 6 mm out from the wall.

Hook the backplate over the top screw and fit the bottom fixing screw into position.

DO NOT fully tighten the screws at this stage, as the fixing holes are elongated to allow for out of square adjustment after the plumbing connections have been completed.

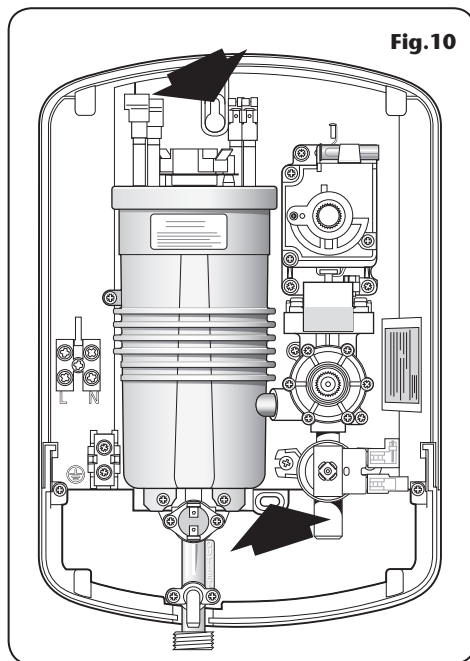

**WARNING!**

**The outlet of the shower acts as a vent and must not be connected to anything other than the hose and showerhead supplied.**

**PLUMBING CONNECTIONS**

***Plumbing to be carried out before wiring***

DO NOT use jointing compounds on any pipe fittings for the installation.

DO NOT solder fittings near the shower unit as heat can transfer along the pipework and damage components

Standard 15mm x 15mm brass compression fittings MUST be used to connect to the inlet of the shower.

**Note:** An additional stopvalve (complying with Water Bylaws/Regulations) MUST be fitted in the mains water supply to the shower as an independent means of isolating the water in order to carry out maintenance or servicing.

**IMPORTANT:** Before completing the connection of the water supply to the inlet of the shower, and in compliance with Water Regulations, flush out the pipework to remove all swarf and system debris. To do this, connect a hose to the pipework and turn on the mains water supply long enough to clear the debris to waste.

***Procedure***

Turn off the water supply either at the mains stopvalve or the isolating stopvalve. Connect the mains water supply to the inlet of the shower via 15 mm copper, stainless steel or plastic pipe using a 15mm x 15mm brass compression fitting.

**Note:** The inlet fitting is designed to enter a compression fitting only. DO NOT use push fit connectors as full engagement cannot be guaranteed. DO NOT use excessive force when making these connections.

Make sure the backplate is square on the wall and tighten the two retaining screws which hold it to the wall.

Turn on the mains water supply and check for leaks in the pipework connection to the shower.

**IMPORTANT:** Using a suitable sealant, always seal around the incoming pipework to prevent water entering the wall.

**Note:** At this stage no water can flow through the unit.

## ELECTRICAL CONNECTIONS

SWITCH OFF THE ELECTRICITY SUPPLY AT THE MAINS.

**Fig.11** shows a schematic wiring diagram.

The cable entry points are shown in **fig.1**.

The cable can be surface clipped, hidden or via 20mm conduit.

**Note:** Conduit entry can only be from rear. Route the cable into the shower unit and connect to the terminal block (**fig.12**) as follows:

Earth cable to terminal marked **E** 

Neutral cable to terminal marked **N**

Live cable to terminal marked **L**

**IMPORTANT:** Fully tighten the terminal block screws and make sure that no cable insulation is trapped under the screws. Loose connections can result in cable overheating.

**Note:** The supply cable earth conductor must be sleeved. The outer sheath of the supply cable must be stripped back to the minimum.

The supply cable must be secured either by routing through conduit or in trunking or by embedding in the wall, in accordance with current IEE regulations.

The use of connections within the unit, or other points in the shower circuit, to supply power to other equipment i.e. extractor fans, pumps etc. will invalidate the guarantee.

**DO NOT switch on the electricity supply until the cover has been fitted.**

**Note:** The elements on UK models are to 240V specification and will give a lower kW rating if the voltage supply is below 240V.

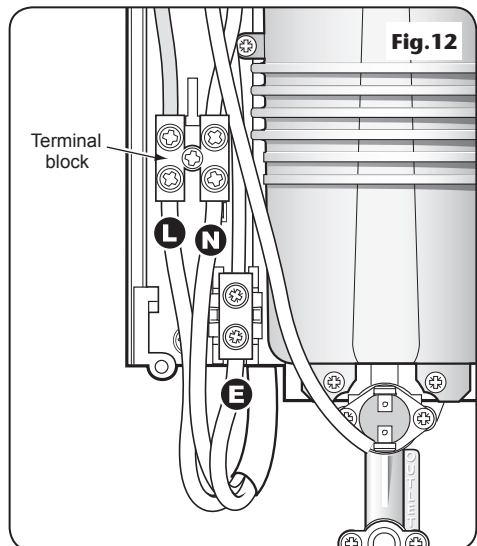
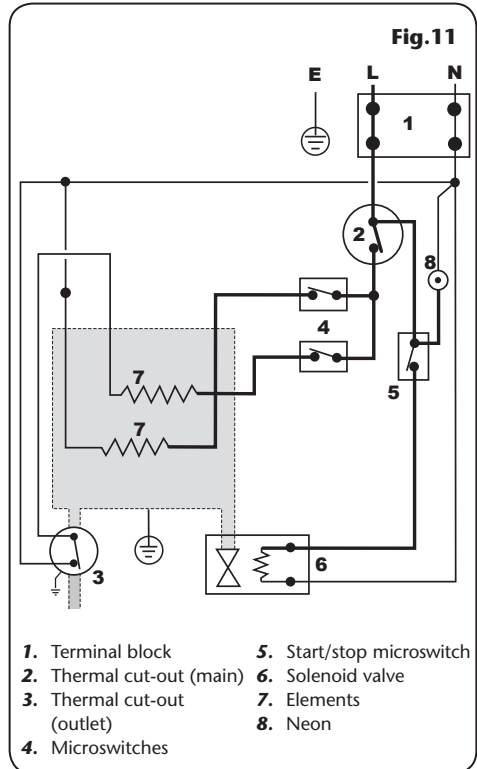

**Fig.13**

Selector spindle

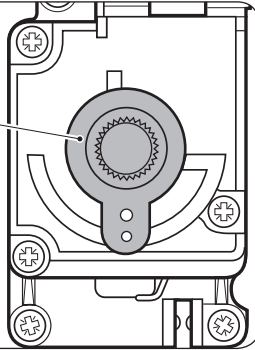

### REPLACING THE COVER

Locate the trimplate into the backplate and secure with the two fixing screws.

The power selector spindle must be aligned as shown (**fig.13**).

To make sure that the temperature control is correctly positioned on the stabilising valve, temporarily place the cover in position so that the splines engage and rotate the temperature control fully anti-clockwise.

Remove the cover and position the temperature control knob so that it points to the '1' position (**fig.14**). Position the power selector to the 'STOP' position (**fig.15**).

Replace the cover squarely to the backplate and guide into position so that the knobs locate correctly into the splined spindles.

Should any difficulty arise, recheck the points above.

Secure the cover in position with the four retaining screws.

**Fig.14**

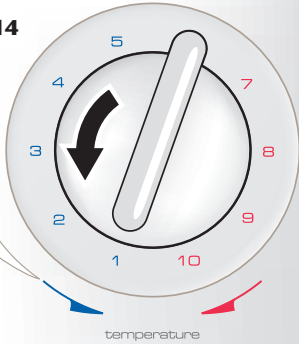

**Fig.15**

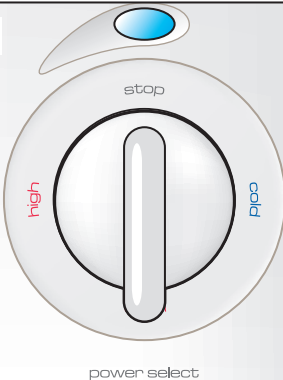

**COMMISSIONING****WARNING!**

**Before normal operation of the shower, it is essential the following commissioning procedure is completed correctly.**

The first operation of the shower is intended to flush out any remaining unit debris, and to make sure the heater unit contains water before the elements are switched on. This operation must be carried out with the flexible hose screwed to the outlet but without the showerhead attached. Make sure the outlet of the flexible hose is directed to waste.

Before turning on the electric and mains water supplies to the shower, make sure that the power selector is at the 'STOP' position (**fig.16**) and the temperature control is rotated fully clockwise to '10', the minimum flow position (**fig.17**).

**Note:** Failure to turn the control to '10' may cause the PRD to operate.

Turn on the mains water supply to the shower at the isolating stopvalve and then turn on the electric supply to the shower at the isolating switch. The power indicator will light.

Switch the power selector to the 'COLD' position (**fig.18**) and wait until water starts to flow from the flexible hose.

Slowly rotate the temperature control fully anti-clockwise to '1', the maximum flow position (**fig.19**).

It will take about thirty seconds for a smooth flow of water to be obtained while air and any debris is being dispersed from the shower.

When a smooth flow of water is obtained, rotate the temperature control from '1' to '10' several times to release any trapped air within the unit.

Once flushing out has been completed, stop the water flow by turning the power selector to the 'STOP' position.

Fit the showerhead to the flexible hose and place in the showerhead holder.

The shower is now ready for normal operation.

**Fig.16****Fig.17****Fig.18****Fig.19**

Fig.20



## OPERATING THE SHOWER

### WARNING!

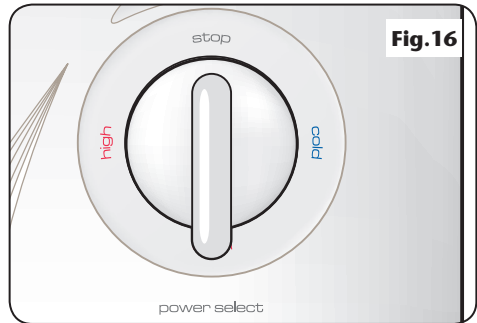
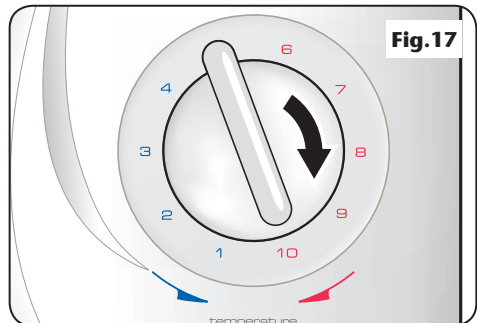
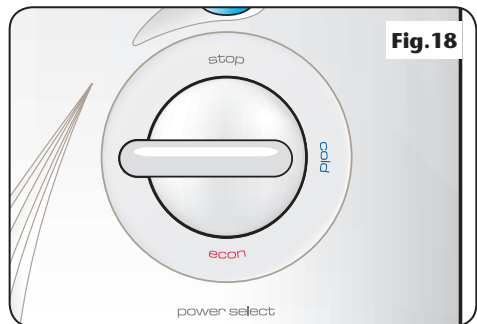
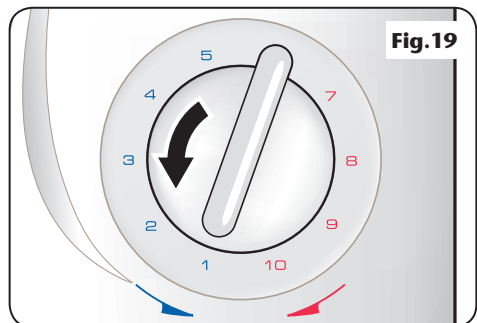
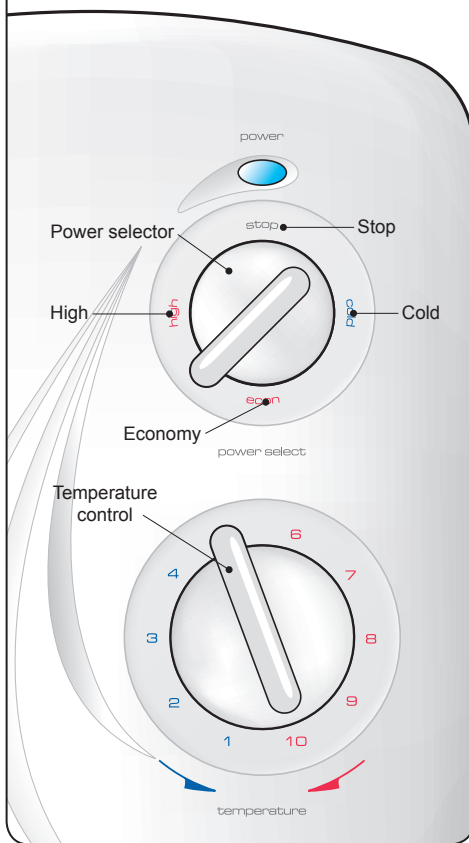
**Before normal operation of the shower, it is essential that the commissioning procedure has been completed correctly.**

### To start the shower

Turning the power selector to the red or blue symbol positions will start water to flow.

### To stop the shower

Switch the power selector to the 'STOP' position and water will cease to flow.

### WARNING!

**If restarting immediately after stopping, be aware that a slug of hot water will be expelled for the first few seconds.**

### To use the power selector

The power selector has four positions – STOP, COLD, ECONOMY and HIGH – as shown in **fig.20**.

**stop** is to switch off the electric and water supply at the shower – no flow or power used.

**cold** is for cold water only. Adjusting the temperature control at this setting will only alter the force of the water from the showerhead. IT WILL NOT ALTER THE WATER TEMPERATURE.

**econ** is the economy setting for using less power during warmer months. Temperature adjustment at this setting is via the temperature control.

**Note:** If the stated flow rate required for the unit cannot be met due to low water pressure, it will be necessary to operate the unit on this setting during the warmer months because of flow rate limitations entering the unit.

**high** is the high setting which allows the highest flow achievable for your preferred temperature. This setting should normally be regarded as optimum shower performance throughout the year. Temperature adjustment at this setting is via the temperature control.

**To adjust the shower temperature**

Alter the water temperature by increasing or decreasing the flow rate of the water through the shower via the temperature control (**fig.20**).

After obtaining your preferred shower temperature, the number can be remembered and left as the normal setting and should only need to be altered to compensate for seasonal changes in ambient water temperature.

**Note:** The preferred number on 'ECONOMY' will give a different temperature to the same number position on 'HIGH'.

**To decrease the shower temperature**

Turn the temperature control anti-clockwise (**fig.21**); this will increase the flow of water through the shower and is indicated by the lower numbers.

**To increase the shower temperature**

Turn the temperature control clockwise (**fig.22**); this will decrease the flow of water through the shower and is indicated by the higher numbers.

**Note:** It is advisable to be certain that the showering temperature is satisfactory by testing with your hand before stepping under the showerhead. There will always be a time delay of a few seconds between selecting a flow rate and the water reaching the stable temperature for that flow rate.

**CAUTION:** It is recommended that persons who may have difficulty understanding or operating the shower controls should not be left unattended while showering. Special consideration should be given to young children and the less able bodied.

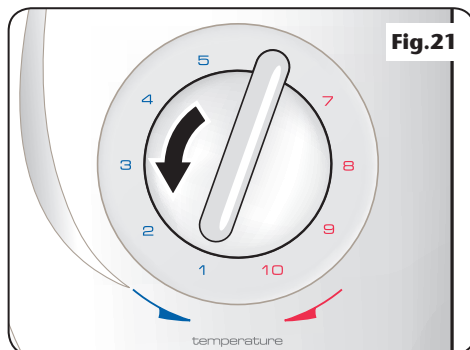

Fig.21

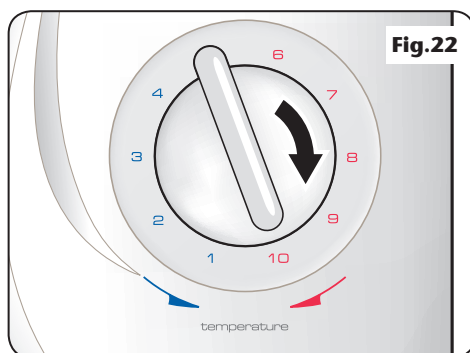

Fig.22

**WARNING!**

**This appliance is not intended for use by persons (including children) with reduced physical, sensory or mental capabilities, or lack of experience and knowledge, unless they have been given supervision or instruction concerning use of the appliance by a person responsible for their safety.**

**Children should be supervised to ensure that they do not play with the appliance.**

Fig.23

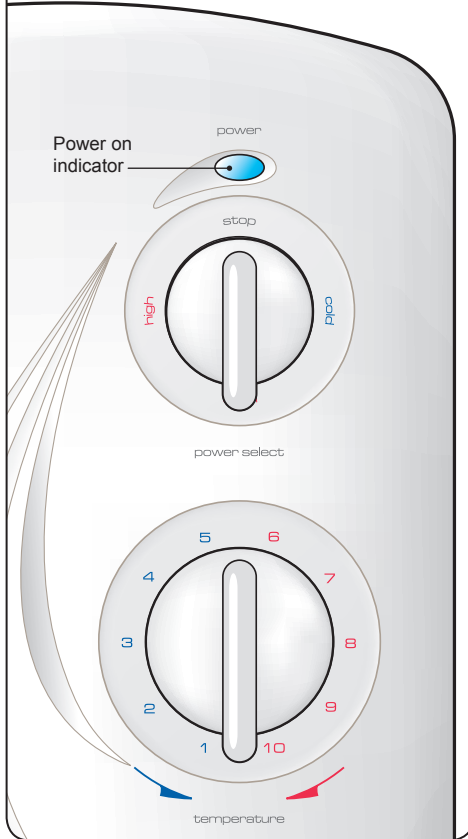

**Note:** In normal use, it is in order to leave the water supply permanently on to the shower unit, but as with most electrical appliances, **the unit must be switched off at the isolating switch when not in use.**

## OPERATING FUNCTIONS

### Power on indicator (fig.23)

When the electricity supply to the shower is switched on at the isolating switch, the 'POWER' indicator will light.

**Note:** Should the safety cut-out device operate, the indicator will remain lit.

### Low water pressure cut-out

If the water pressure falls below the minimum required for correct operation of the shower, power will be switched off to the heating elements preventing any maintained temperature rises (water will continue to flow).

Power will automatically be restored when adequate water pressure returns.

### Temperature limiter

During normal operation if an overheat temperature is sensed, power to the elements will be reduced. Water will continue to flow. When the temperature has cooled sufficiently, power to the elements will be automatically restored to the previous setting at the time of interruption.

### Safety cut-out

The unit is fitted with a non-resettable thermal cut-out safety device. In the event of abnormal operation which could cause unsafe temperatures within the unit, the device will disconnect the heating elements. It will require a visit from a qualified engineer to determine the nature of the fault and replace the safety device, once the unit has been repaired.

**INSTRUCTIONS FOR INSTALLERS AND SERVICE ENGINEERS ONLY**

**CLEANING THE INLET FILTER**

It is recommended that the filter is periodically cleaned in order to maintain the performance of the shower. It is essential that this operation is carried out by a competent person.

**IMPORTANT:** Before servicing, switch off the electricity supply at the mains.

Remove the cover. The inlet filter is situated in the inlet pipe, which is part of the solenoid valve **(fig.24)**.

To access the filter, remove the trimplate then disconnect and remove the compression fitting.

Also, depending on the incoming pipework arrangements, if there is not enough slack in the pipework, it could mean the removing the unit from the wall.

When cleaning the filter, DO NOT use a sharp object, as it will cause damage. It is preferable to use an old toothbrush or similar.

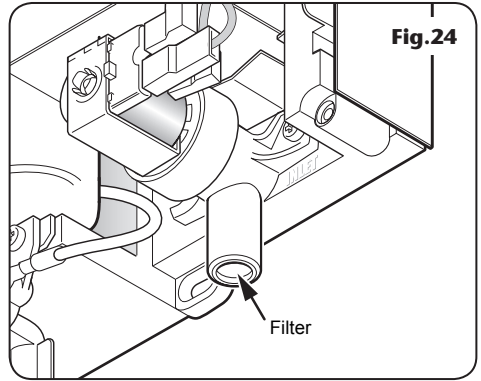

**SPARE PARTS**

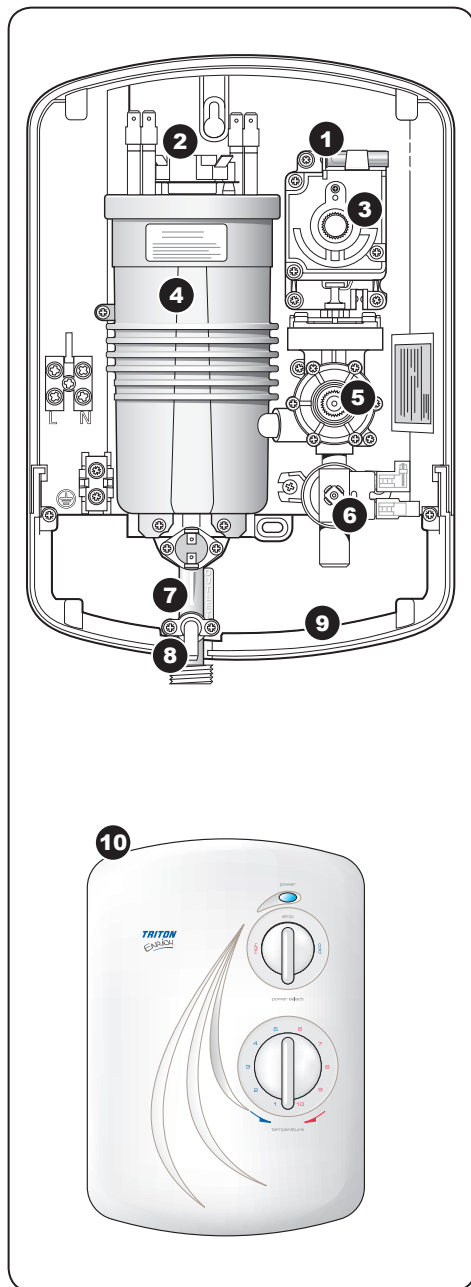

<b>Ref.</b>	<b>Description</b>	<b>Part No.</b>
1.	Power neon	82300980
2.	Thermal cut-out (main)	22010070
3.	Switch carriage	7052197
	– Camshaft assembly	82800480
	– Microswitch and wire assembly	82300970
4.	Can assembly - 8.5kW	P07810700
5.	Stabiliser valve assembly	P07810800
6.	Solenoid valve assembly	83300450
7.	Outlet pipe assembly (incl. terminal block & wires)	S09201101
8.	Pressure Relief Device (PRD)	82800450
9.	Trimplate - White	7052921
10.	Front cover assembly	P14710600

**FAULT FINDING**

**IMPORTANT:** Switch OFF the electricity at the mains supply and remove the circuit fuse before attempting any fault finding inside the unit.

<b>Problem/Symptom</b>	<b>Cause</b>	<b>Action/Cure</b>
<b>1</b> Shower inoperable, no water flow.	<b>1.1</b> Interrupted power supply.	<b>1.1.1</b> Blown fuse or circuit breaker. Check supply. Renew or reset fuse or circuit breaker. If it fails again, consult a qualified electrician. <b>1.1.2</b> Power cut. Check other appliances and if necessary, contact local Electricity Supply Co.
	<b>1.2</b> Unit malfunction.	<b>1.2.1</b> Have unit checked. Ring Customer Service.
<b>2</b> Water too hot.	<b>2.1</b> Not enough water flowing through the shower.	<b>2.1.1</b> Increase flow rate via temperature control. <b>2.1.2</b> Blocked showerhead — clean or replace blocked sprayplate in showerhead.
	<b>2.2</b> Blockage in supply.	<b>2.2.1</b> Check if stop valves are fully open. Check if a blockage in the inlet filter.
	<b>2.3</b> Increase in ambient water temperature.	<b>2.3.1</b> Readjust flow rate to give increased flow. <b>2.3.2</b> Select 'ECONOMY' power.
<b>3</b> Water temperature cycling hot/cool at intervals.	<b>3.1</b> Heater cycling on temperature limiter.	<b>3.1.1</b> See 'Water too hot' causes 2.1, 2.2 and 2.3 and their appropriate action/cures. If it continues contact Triton Customer Service.
<b>4</b> Water too cool or cold.	<b>4.1</b> Too much flow.	<b>4.1.1</b> Reduce flow rate via temperature control.
	<b>4.2</b> Water pressure below minimum required (see rating label).	<b>4.2.1</b> Is water supply mains or tank fed?
		<b>4.2.2</b> If tank fed, replumb to mains water supply or see 4.2.4.
		<b>4.2.3</b> If mains fed, make sure that mains stopvalve is fully open and that there are no other restrictions in the supply while shower is in use, or see 4.2.4.
	<b>4.2.4</b> Fit pump to give minimum pressure (see rating label). Contact Customer Service for advice.	
<b>4.3</b> Reduction in ambient water temperature.	<b>4.3.1</b> Readjust flow rate to give reduced flow. <b>4.3.2</b> Select 'HIGH' power.	
<b>4.4</b> Electrical malfunction.	<b>4.4.1</b> Have unit checked by suitably qualified electrician or contact Triton Customer Service.	
<b>4.5</b> Safety cut-out operated.	<b>4.5.1</b> Thermal safety cut-out device has operated. Have the unit checked by a suitably qualified engineer or contact Customer Service.	

**FAULT FINDING**

<b>Problem/Symptom</b>	<b>Cause</b>	<b>Action/Cure</b>
<b>5</b> Shower varies from normal temperature to cold during use.	<b>5.1</b> Water pressure has dropped below minimum required.	<b>5.1.1</b> Wait until the water pressure resumes to normal.
<b>6</b> Pressure relief device has operated (water ejected from PRD tube).	<b>6.1</b> Blocked showerhead. <b>6.2</b> Twisted/blocked flexible shower hose. <b>6.3</b> Showerhead not removed while commissioning.	<b>6.1.1</b> Clean or replace blocked sprayplate in showerhead and then fit new PRD. <b>6.2.1</b> Check for free passage through hose. Replace the hose if necessary and fit new PRD. <b>6.3.1</b> Fit new PRD. Commission unit with showerhead removed.
<b>7</b> Shower fails to shut off.	<b>7.1</b> Faulty power selector. <b>7.2</b> Debris in the solenoid.	<b>7.1.1</b> Replace power selector. <b>7.2.1</b> Replace solenoid valve.

**Note:** Identify the cause of operation before fitting a new PRD unit. When fitting a new PRD, follow the commissioning procedure.

**It is advised all electrical maintenance/repairs to the shower should be carried out by a suitably qualified person.**

**In the unlikely event of unit failure other than detailed in the fault finding page, please contact Customer Service for advice.**



## UK SERVICE POLICY

In the event of a product fault or complaint occurring, the following procedure should be followed:

1. Telephone Customer Service on **0844 980 0750** having available, your details including post code, the model number and power rating of the product, together with the date of purchase.
2. Based on information given over the telephone, a Triton Customer Service Advisor will attempt to diagnose the fault and confirm whether a site visit from a qualified service engineer is required.
3. All products attended to by a Triton service engineer must be installed in full accordance with the Triton installation guide applicable to the product. (*Every product pack contains an installation guide, however, they can also be bought via our Customer Service Spares Department.*)
4. Our engineer will require local parking and if a permit is required this must be available to the engineer on arrival at the call.
5. It is essential that you or an appointed representative (*who must be over 18 years of age*) is present for the duration of the service engineer's visit. If the product is in guarantee you must produce proof of purchase.
6. Where a call under the terms of guarantee has been booked and the failure is not product related (*i.e. scaling and furring, incorrect water pressure, pressure relief device operation or electrical/plumbing installation fault*) a charge will be made. A charge will also be issued if nobody is at home when the service engineer calls or adequate parking/permit is not available.
7. If the product is no longer covered by the guarantee an up front fixed fee will be charged before the site visit.
8. Should proof of purchase not be available on an "in-guarantee" call, or should the service engineer find that the product is no longer under guarantee, the engineer will charge the same fixed price and the customer will be expected to pay the engineer before he leaves. If payment is not made on the day an administration charge will be added to the fixed charge.
9. If a debt is outstanding from a previous visit, or from any other Triton purchase. Triton reserves the right to withhold service until the debt has been settled.
10. Triton takes the health, safety and wellbeing of its employees very seriously and expects customers to treat all staff members with respect. Should any employee feel threatened or receive abuse, either verbally or physically, Triton reserves the right to withhold service and will support the employee with a legal prosecution.

### Replacement Parts Policy

**Availability:** It is the policy of the manufacturer to maintain parts availability for the duration of production and a period of five years thereafter, in accordance with industry standards.

Spare parts are available via our website, [www.tritonshowers.co.uk](http://www.tritonshowers.co.uk), or by telephoning Triton Customer Service Spares Department. Payment should be made by credit/debit card (*excluding American Express or Diners Card*).

Payment can also be made by pre-payment of a pro forma invoice by cheque or money order.

Triton Showers  
Triton Road  
Nuneaton  
Warwickshire CV11 4NR

*Triton is a division of Norcross Group (Holdings) Limited*

## TRITON STANDARD GUARANTEE

Triton guarantee this product against all mechanical and electrical defects arising from faulty workmanship or materials for a period of two years for domestic use only, from the date of purchase, provided that it has been installed by a competent person in full accordance with the fitting instructions.

Any part found to be defective during this guarantee period we undertake to repair or replace at our option without charge so long as it has been properly maintained and operated in accordance with the operating instructions, and has not been subject to misuse or damage.

This product must not be taken apart, modified or repaired except by a person authorised by Triton. This guarantee applies only to products installed within the United Kingdom and does not apply to products used commercially. This guarantee does not affect your statutory rights.

### What is not covered:

1. Breakdown due to: *a)* use other than domestic use by you or your resident family; *b)* wilful act or neglect; *c)* any malfunction resulting from the incorrect use or quality of electricity, gas or water or incorrect setting of controls; *d)* failure to install in accordance with this installation guide.
2. Repair costs for damage caused by foreign objects or substances.
3. Total loss of the product due to non-availability of parts.
4. Compensation for loss of use of the product or consequential loss of any kind.
5. Call out charges where no fault has been found with the appliance.
6. Call out charges where the water supply cannot be isolated, this includes consequential losses arising from unserviceable supply valves.
7. The cost of repair or replacement of pressure relief devices, showerheads, hoses, riser rails and/or wall brackets, isolating switches, electrical cable, fuses and/or circuit breakers or any other accessories installed at the same time.
8. The cost of routine maintenance, adjustments, overhaul modifications or loss or damage arising therefrom, including the cost of repairing damage, breakdown, malfunction caused by corrosion, furring, pipe scaling, limescale, system debris or frost.

**Customer Service:** ☎ **0844 980 0750**

**Trade Installer Hotline:** ☎ **0844 980 0730**

**Fax:** **0844 980 0744**

[www.tritonshowers.co.uk](http://www.tritonshowers.co.uk)

**E-mail:** [serviceenquiries@tritonshowers.co.uk](mailto:serviceenquiries@tritonshowers.co.uk)

**Extended Warranty AVAILABLE NOW. Call 0844 980 0740 for more details.**