

**TRITON**

**THAMES**  
**Thermostatic vertical mixer shower**

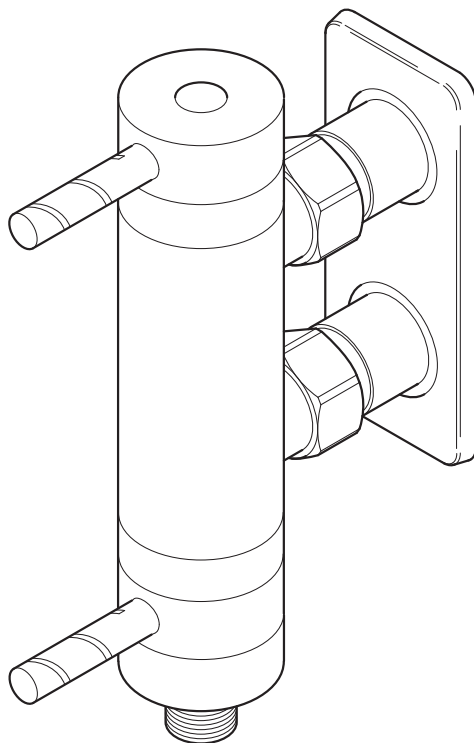

**Installation and  
operating instructions**

INSTALLERS PLEASE NOTE THESE INSTRUCTIONS ARE TO BE LEFT WITH THE USER

<b>CONTENTS</b>	<b>Page</b>
Main components .....	1
Introduction .....	2 -3
Typical domestic installations.....	4 - 6
Preparing the mixer valve .....	7
Siting of the shower.....	7
Supply pipework.....	8
Fitting the mixer .....	9 - 10
To fit the flow regulator .....	11
Final leak testing .....	11
Commissioning.....	11
Temperature adjustment range.....	12
Adjusting the maximum temperature setting.....	12
Operating the shower.....	13
Approvals - Flow chart .....	14
Dimensions.....	15
Spare parts .....	16 - 17
Maintenance .....	18
Fault Finding.....	19 - 20
Guarantee, service policy, etc.....	rear cover

To check the product suitability for commercial and multiple installations, please contact Triton's specification advisory service before installation.

Telephone: 0844 980 0730

Facsimile: 0844 980 0744

E mail: [technical@tritonshowers.co.uk](mailto:technical@tritonshowers.co.uk)

**MAIN COMPONENTS**

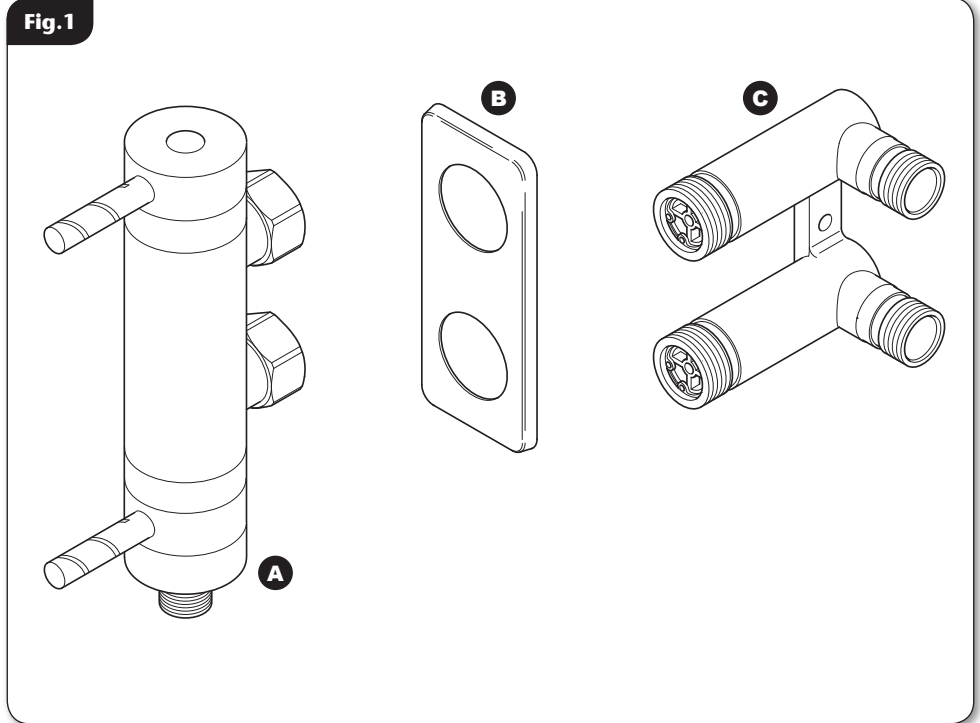

**Fig. 1**

- A.** Vertical thermostatic mixer valve
- B.** Cover trim
- C.** Mixer mounting bracket

All dimensions listed in this fitting book regarding the product and installation are approximate.

\*All kits are for illustration purposes only and are not supplied unless otherwise stated.

### INTRODUCTION

This book contains all the necessary fitting and operating instructions for your Triton mixer shower. Please read them carefully and read through the whole of this book before beginning your installation.

The shower installation must be carried out by a suitably competent person and in sequence of this instruction book.

Care taken during the installation will give a long and trouble free life from your mixer shower.

### SITE REQUIREMENTS

The installation must be in accordance with Water Regulations and Bylaws.

#### Water pressure requirements

*Running water pressure:*

Low pressure	- 0.1 bar min. 1.0 bar max.
High pressure	- 0.5 bar min. 5.0 bar max.

*Maximum static water pressure:*

Low & High pressure	- 10 bar
---------------------	----------

This mixer shower is designed for use with higher pressure systems found in the UK up to a maximum of 5 bar running pressure.

For effective operation of the internal seals, the maximum static pressure must not be exceeded.

#### Pressure reducing valve

On sites where the running pressure is above 5 bar, the use of a suitably sized pressure reducing valve fitted in the cold mains supply pipe work can provide nominally equal pressures at the mixer shower.

Replacement parts can be ordered from Triton Customer Service. See 'spare parts' for details and part numbers.

#### Water minimum flow rate

For best performance within the specified running pressure range a minimum flow of 8 litres per minute should be available to both inlets.

#### Water temperature requirements

Maximum hot water temperature: = 80°C

Recommended maximum: = 65°C

Minimum hot water temperature: = 52°C

Maximum cold water temperature: = 20°C

**The mixer shower MUST NOT be subjected to water temperatures above 80°C.**

BS 6700 recommends that the temperature of stored water should never exceed 65°C.

A stored water temperature of 60°C is considered sufficient to meet all normal requirements and will minimise the effects of scale in hard water areas.

#### Water temperature adjustment and thermal safety

The mixed water temperature can be adjusted from cold through to a top limit which must be preset during installation with full anti-scald protection throughout the range (35°C to 40°C) providing the hot water temperature at the inlet remains 10°C above the outlet temperature.

Should there be a loss of flow to either incoming supply then- water from the shower will stop or be reduced until both supplies are restored.

### SAFETY WARNINGS

- DO NOT** choose a position where the shower could become frozen.
- DO NOT** connect this mixer shower to any form of tap or fitting not recommended by the manufacturer.
- DO NOT** allow the inlet pressure or flow rates to operate outside the guidelines laid out in 'site requirements'.
- DO NOT** connect the mixer shower to a gravity hot supply and a mains cold supply (or vice versa).

### PLUMBING REQUIREMENTS

**DO NOT** use jointing compounds on any pipe fittings for the installation.

**DO NOT** solder fittings near the mixer unit as heat can transfer along the pipework and damage the mixer valve.

#### **IMPORTANT:**

- The layout and sizing of pipework **MUST** be such that nominally equal inlet supply pressures are achieved and the effects of other draw-offs are minimised.
- The pipe-work should be installed such that other taps and appliances being operated elsewhere on the premises do not significantly affect the flow
- When connecting pipe-work avoid using tight 90° elbows; swept or formed bends will give the best performance.
- The hot water pipe entry must be made to inlet, marked HOT, 'H' or with a red/orange label.
- Suitable isolating valves (complying with Water Regulations and Bylaws) must be fitted on the hot and cold water supplies to the shower as an independent means of isolating the water supplies should maintenance or servicing be necessary.
- It is preferable to flush the pipe-work to clear the system of debris and check for leaks before connecting to the mixer.
- The mixer inlets contain removable filters that may become blocked if debris is not flushed through before fitting.

#### **(Commercial applications)**

- Triton recommends for all commercial applications that, easily accessible, in-line filters are used to aid maintenance.

### **Hard water areas**

- a. If it is intended to operate the shower in areas of hard water (above 200-ppm temporary hardness), a scale inhibitor may have to be fitted. For advice on the Triton scale inhibitor, please contact Customer Service.
- b. For best performance the showerhead **MUST** be regularly cleaned to remove scale and debris.

### WATER SYSTEM REQUIREMENTS

**This mixer shower is suitable for: -**

- Gravity systems.
- Pumped gravity systems.
- Fully modulating type combination boilers.
- Multi-point hot water heaters.
- Thermal storage.
- Unvented systems.

When installing this mixer with a Combination or multi-point boiler, it may be necessary to install flow regulation.

Check that the appliance is capable of delivering hot water at a minimum switch-on flow rate of 3 litres per minute. At flow rates between 3 and 8 litres per minute, the appliance must be capable of raising the water temperature to 52°C (minimum).

Water temperature at the inlet of the mixer valve must remain relatively constant when flow rate adjustments are made (refer to the appliance-operating manual to confirm compatibility with this mixer shower).

Where thermal store systems and instantaneous gas water heaters are used, if excessive draw-off take place the appliance may not be able to maintain an adequate output temperature. This could result in the shower temperature becoming noticeably cooler.

Flow regulators can be fitted to the inlet pipework with high-pressure water systems to reduce flow rate and assist economy.

The hot supply temperature **MUST** remain a minimum of 10°C hotter than the required blend temperature for optimum performance.

**\*Fig.2**

\*(diagrammatic view – not to scale)

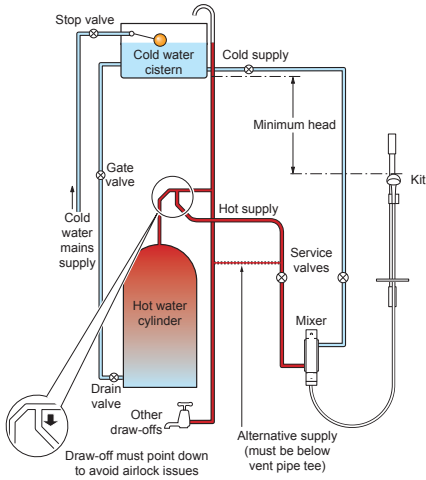

**TYPICAL DOMESTIC INSTALLATIONS**

**Domestic gravity fed systems (fig.2)**

The shower control MUST be fed from a cold water cistern and hot water cylinder providing nominally equal pressures. There must be a minimum of one metre head of water. The minimum head distance is measured from the base of the cold water cistern to top of the showerhead.

If valves are gravity fed then supply pressure should be verified to ensure conditions of use are appropriate for the valve.

**Pumped gravity fed systems (fig.3)**

The shower control MUST be fed from a cold water cistern and hot water cylinder providing nominally equal pressures.

The mixer may be used with a gravity fed system with a pump to boost pressures as shown; please refer to the pump installation guide to establish the minimum head requirements for automatic operation of the pump

**\*Fig.3**

\*(diagrammatic view – not to scale)

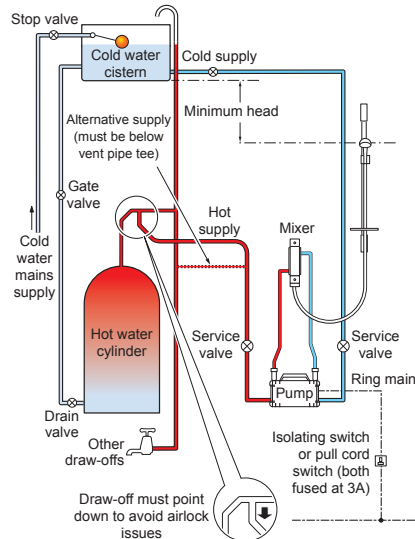

**Instantaneous gas-heated systems, e.g. combination boilers (fig.4)**

The shower control MUST be installed with a multi-point gas water heater or combination boiler of a fully modulating design (i.e. to maintain relatively stable hot water temperatures).

A drop tight pressure reducing valve MUST be fitted if the supply pressures exceed 5 bar running.

An expansion vessel **MAY** be fitted, and regularly maintained, to prevent the shower mixer being damaged by excess pressures. This may already be installed within the boiler (check with manufacturer) and is in addition to the normally larger central heating expansion vessel.

**Unvented mains pressure systems (fig.5)**

The shower control can be installed with an unvented, stored hot water cylinder.

For systems with no cold water take off after the appliance reducing valve, it will be necessary to fit an additional drop tight pressure-reducing valve when the mains pressure is over 5 bar. The drop tight pressure reducing valve must be set at the same value as the unvented package pressure reducing valve.

Note: An additional expansion vessel may be required if a second pressure-reducing valve is installed. This does not apply to packages with a cold take off after the pressure-reducing valve to the cylinder.

**\*Fig.4**

*\*(diagrammatic view – not to scale)*

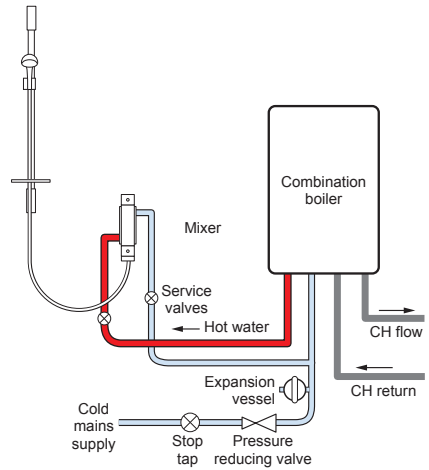

**\*Fig.5**

*\*(diagrammatic view – not to scale)*

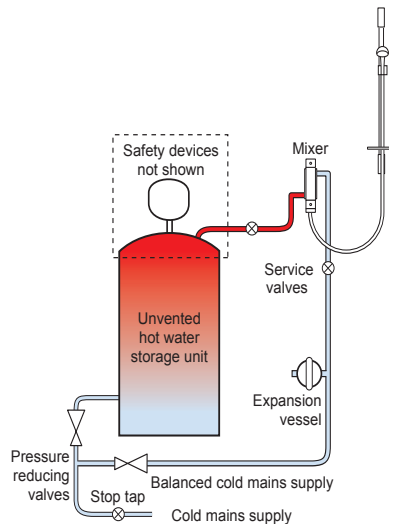

**\*Fig.6**

*\*(diagrammatic view – not to scale)*

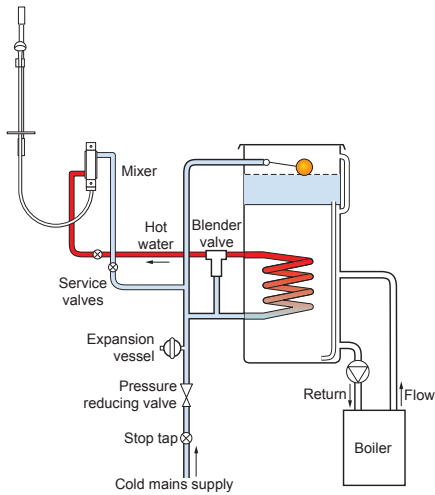

**Mains pressurised thermal store systems (fig.6)**

Packages of this type, fitted with a tempering valve (blender valve) can be used. A drop tight pressure reducing valve MUST be fitted if the supply pressures exceed 5 bar running.

An expansion vessel MUST be fitted, and regularly maintained, to ensure, the unit, is not damaged by excess pressures. This may already be installed externally or internally within the thermal store (check with thermal store manufacturer).

## INSTALLATION

### PREPARING THE MIXER VALVE

Check the contents to make sure all parts are present.

Before starting the mixer installation, make sure all the openings on the valve are carefully covered to stop ingress of any debris, etc. while routing the supply pipework.

The shower valve is suitable for exposed installation onto solid wall, a stud partition wall, dry lined wall or fixing to a laminate cubicle or panel.

### SITING OF THE SHOWER AND ACCESSORIES

Refer to **(fig.7)** for correct siting of the shower.

The mixer valve should be positioned, as detailed, with all controls within comfortable reach of the user.

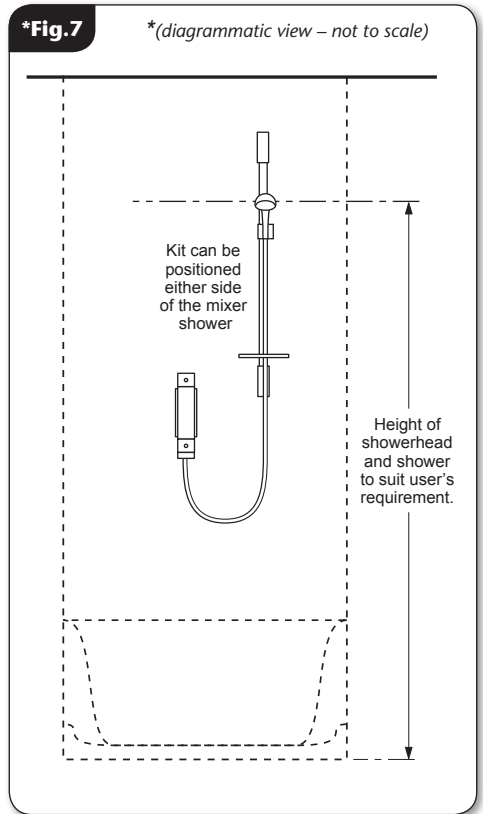

All dimensions listed in this fitting book regarding the product and installation are approximate.

Fig.8

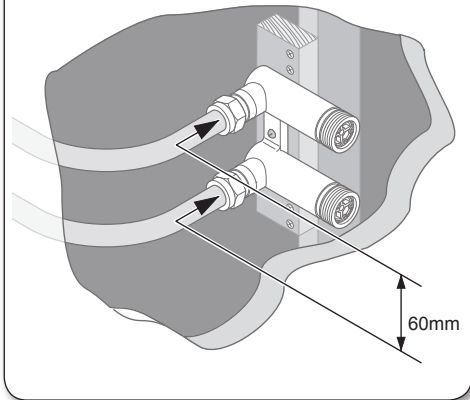

## SUPPLY PIPE WORK

Complete the pipework to the shower area having decided on the position of the shower and direction of pipe entry (for example rising, falling or rear entry)

The hot and cold water pipes should not be permanently attached to the wall within one metre of the valve, before installation is complete, to allow for final adjustment of the valve position.

The hot and cold water supply inlet centres of the bracket are 60mm (approximately) apart (**fig.8**).

### WARNING!

Check there are no hidden cables or pipes before drilling holes for wall plugs. Use great care when using power tools near water. The use of a residual current device (RCD) is recommended.

Fig.9

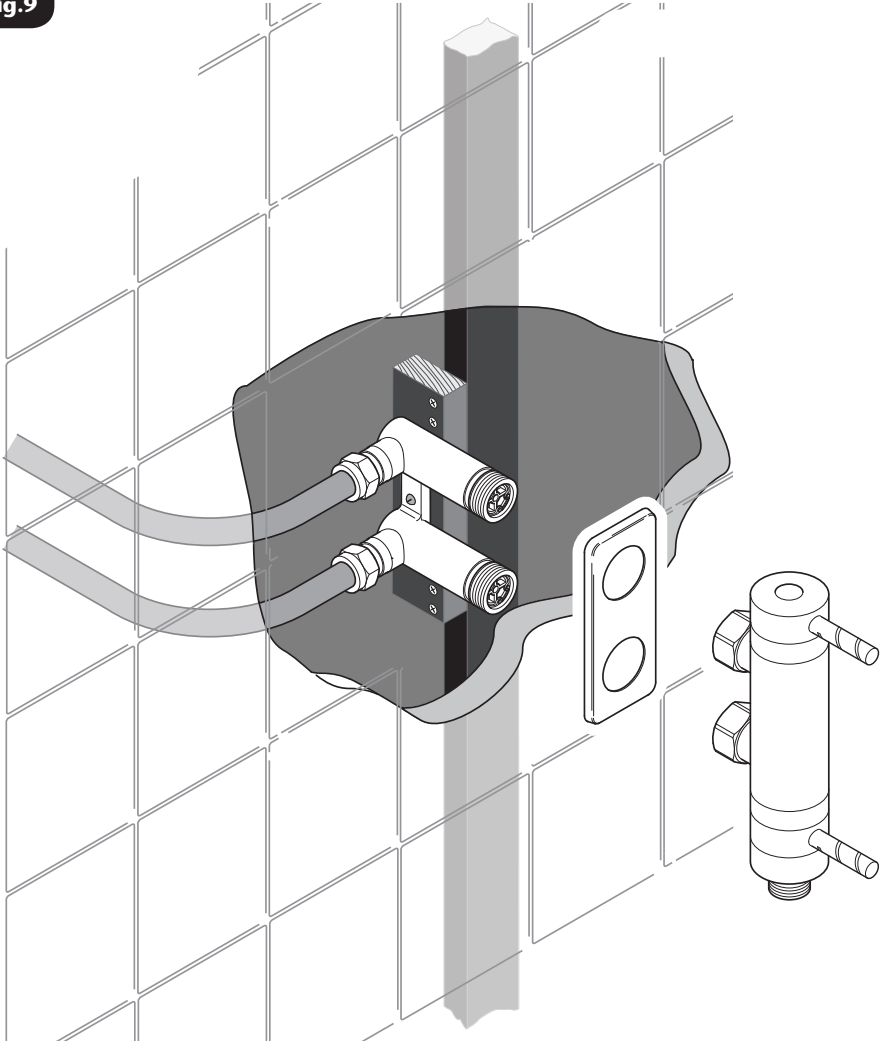
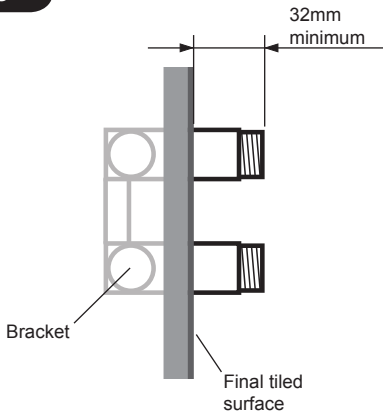

Illustration is to give an example of the secure fixing required.  
This book does not have the scope to cover all installation options.

**Fig.10**



*Note: it is advised that there is at least **32mm** from the face of the mixer threads to the final tiled surface of the wall.*

## FITTING THE MIXER

**Note:** The mixer bracket requires secure fixing - (**fig.9**) gives an example of the fixing required. The mixer bracket **MUST** be supported by a baton or noggin.

The mixer **MUST** be fitted vertically with the HOT water going to the inlet, marked HOT, 'H' or with a red/orange label and connect the cold water supply to the inlet marked COLD, 'C' or blue label.

- Once the height and position of the mixer shower and the shower kit has been established, the mixer bracket will need to be installed.

### IMPORTANT:

**Make sure that all supply pipework has been flushed through before fitting the mixer.**

### Fitting the mixer

**Note:** It is advisable to leak test the incoming pipework before making good the wall.

- Fit the mixer to the bracket and tighten the fittings.  
Make sure that the mixers flow and diverter controls are in the 'OFF' position - see (**fig.13 & 15**).
- Turn on both of the water inlet supplies to the mixer.
- Once it has been established that there are no leaks, isolate the water supplies and remove the mixer from the bracket.
- Make good the wall and fit the mixer face plate.
- Fit the mixer to the bracket and tighten the fittings.

### Flow regulation

Flow regulator is supplied for use with high-pressure water systems and may be fitted with any of the systems listed to reduce flow rate and assist economy.

#### To fit the flow regulator (fig.11)

**Note: the flow regulators are only designed to work in one direction.**

The flow regulator should be inserted into the bottom outlet of the mixer shower.

### FINAL LEAK TESTING

Fit the hose to the outlet and direct it to waste. Open the isolating valves to the shower and check for leaks. Remedy any leaks found.

### COMMISSIONING

Important: Make sure that all supply pipework has been flushed through before commissioning. Start the water flow by rotating the flow control. Make sure that both the hot and cold water supplies are fully open and at (or near to) their design temperature and pressures, and are within the requirements as stated.

Make sure the temperature control is at the maximum temperature setting.

Allow the shower to run at the maximum temperature setting until the water temperature has stabilised. Rotate the temperature control until your desired maximum showering temperature is reached.

The mixer has a temperature stop to prevent accidental rotation to higher temperatures. This is adjustable to provide a maximum temperature of 35°C – 45°C and should be checked on site to guarantee user safety.

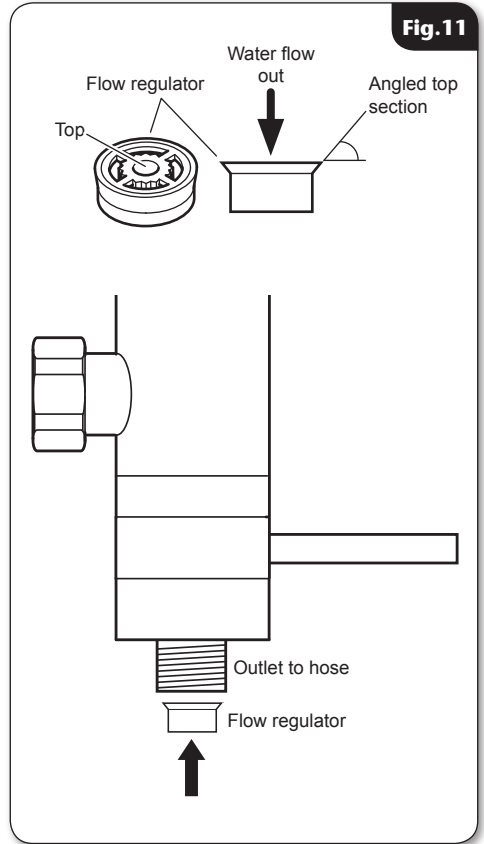
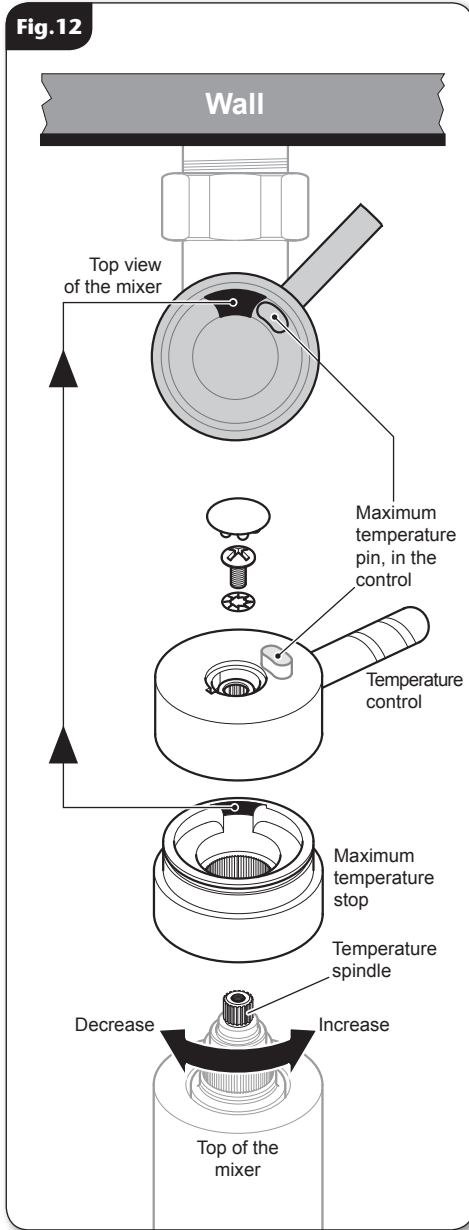

Fig. 12



## TEMPERATURE ADJUSTMENT RANGE

The mixed water temperature can be adjusted from cold through to a top limit (which can be preset during installation – factory set at approximately 38°C) with full anti-scald protection throughout the range.

### Adjusting the maximum temperature override setting

- Remove the temperature control (top of the mixer) by removing the end cap and unscrewing the retaining screw (**fig. 12**).
- Turn the flow control to full flow.
- Remove the temperature control and maximum temperature stop and adjust the temperature valve spindle until the desired maximum temperature is achieved (**fig. 12**) - turning the spindle clockwise will **Decrease** the maximum temperature, turning the spindle anti-clockwise will **Increase** the maximum temperature.
- When you are satisfied with the temperature, turn the flow control off.
- Refit in the reverse order with the maximum temperature stop at the rear.
- The maximum temperature pin in the control should be positioned as close as it can be to the right hand side of the maximum temperature stop.
- Once the lever is in place, secure with the screw and replace the end cap.

### Recommended outlet temperatures

The BuildCert TMV scheme recommends the following set maximum mixed water outlet temperatures for use in all premises:

44°C - for bath fill but see notes below.

41°C - for showers.

41°C - for washbasins.

38°C - for bidets.

The mixed water temperatures must never exceed **46°C** at terminal fitting.

The British Burns Association recommends **37** to **37.5°C** as a comfortable bathing temperature for children. In premises covered by the Care Standards Act 2000, the maximum mixed water outlet temperature is **43°C**.

### OPERATING THE SHOWER

- To start the mixer, rotate the On/Off flow control (bottom lever) clockwise until it stops for maximum flow (**fig.13**).
- To stop the water flow, rotate the On/Off flow control anti-clockwise until it stops (**fig.13**).
- To adjust the water temperature, rotate the temperature control (top lever) – clockwise for colder or anti-clockwise for hotter (**fig.14**).

Fig.13

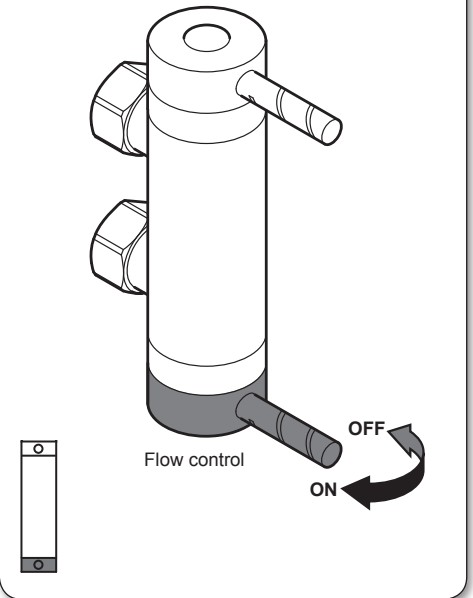
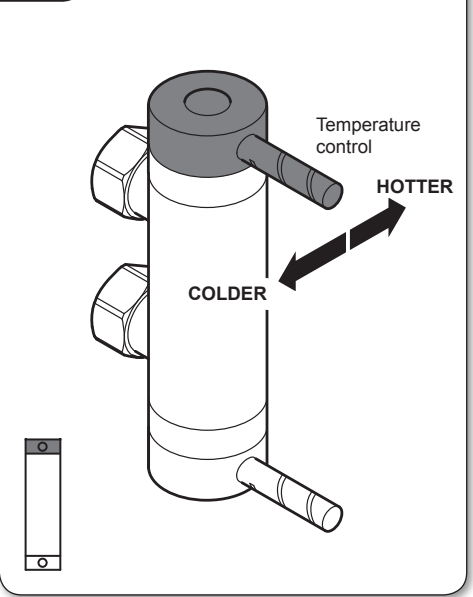

Fig.14



## APPROVALS

This mixer valve has been designed to comply with the requirements of: **BS EN 1111**  
**BS EN 1287**  
**WRAS**

## FLOW CHART

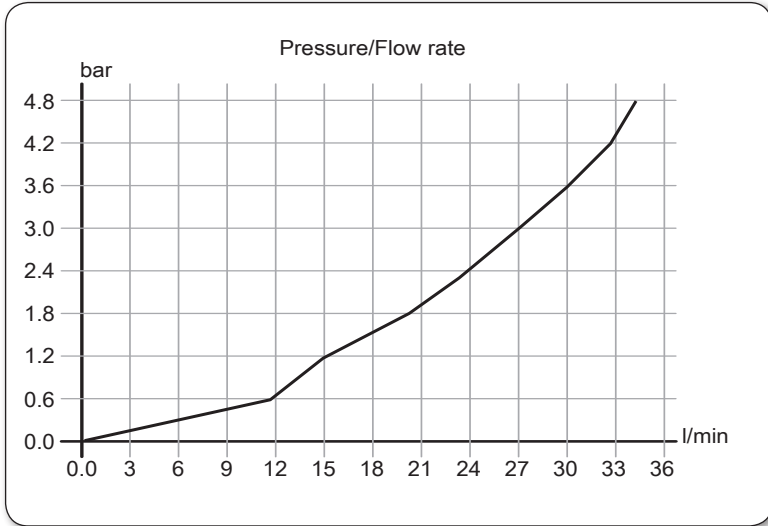

- Flow rate at 38°C
- Flow control fully open
- Open outlet
- No flow regulator fitted

**DIMENSIONS**

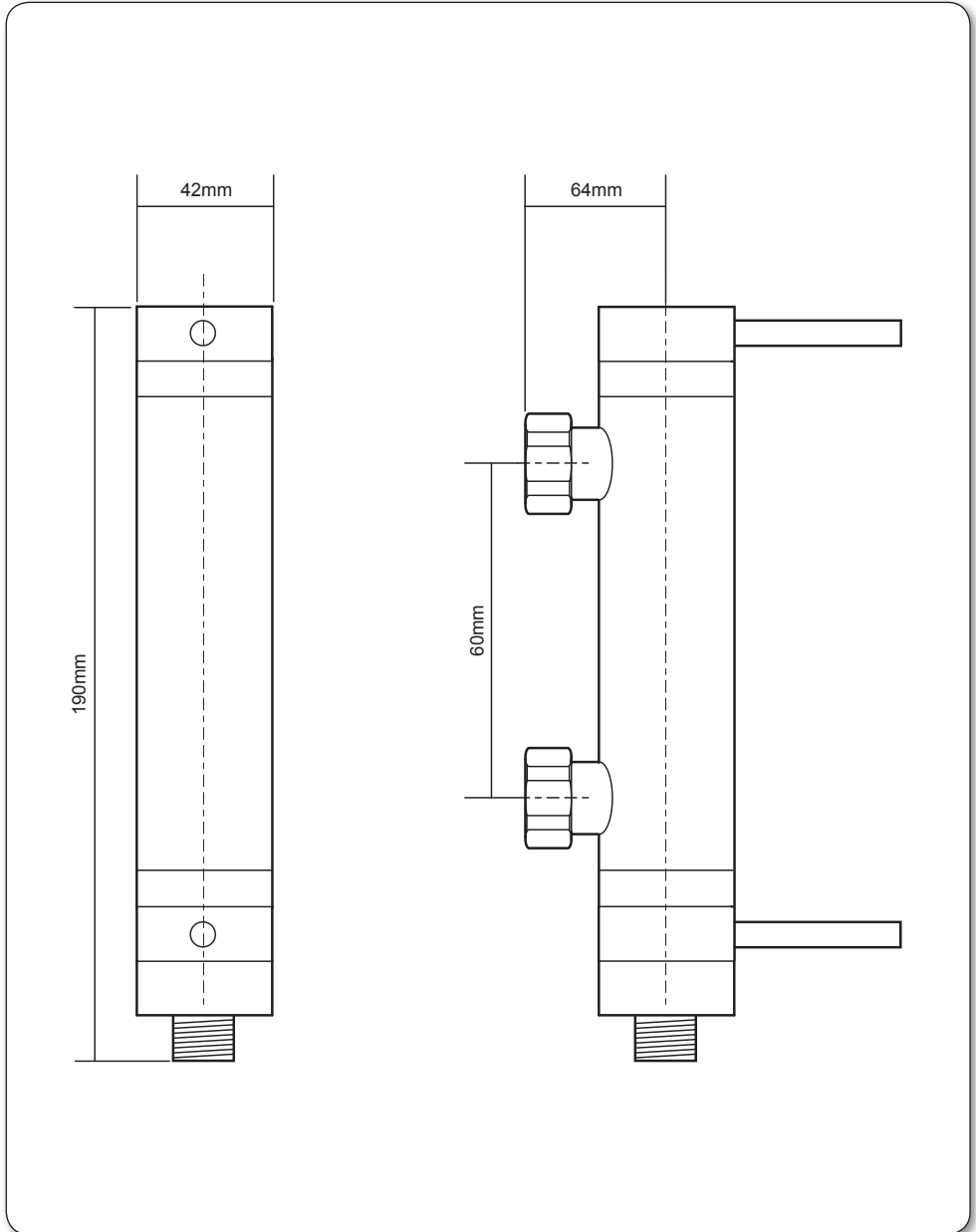

All dimensions listed in this fitting book regarding the product and installation are approximate.

## Vertical bar mixer shower

### SPARE PARTS

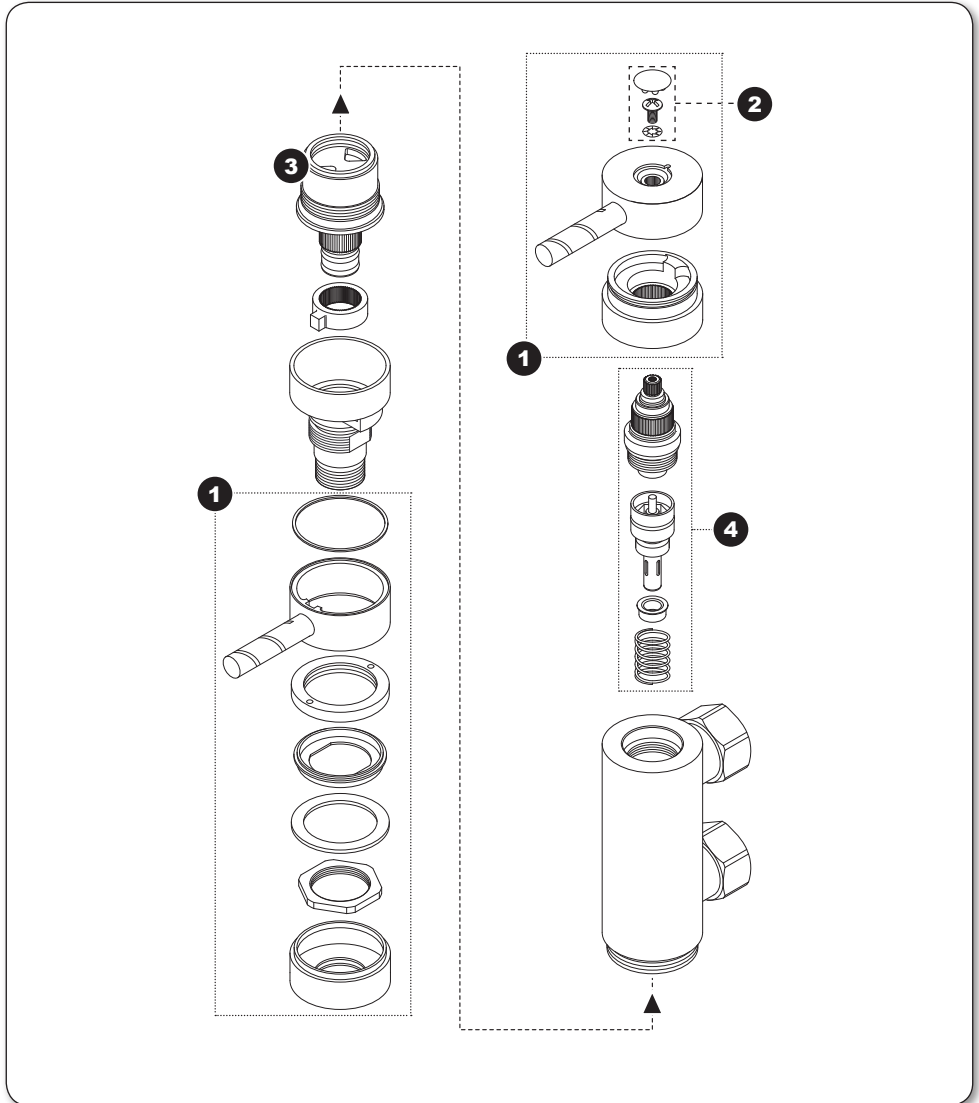

<b>Ref.</b>	<b>Description</b>	<b>Part No.</b>	<b>Ref.</b>	<b>Description</b>	<b>Part No.</b>
1.	Closure knob & flow knob	86003400	3.	Flow valve	83314160
2.	Trim and screw kit	83314180	4.	Thermostatic assembly	83314170

**SPARE PARTS**

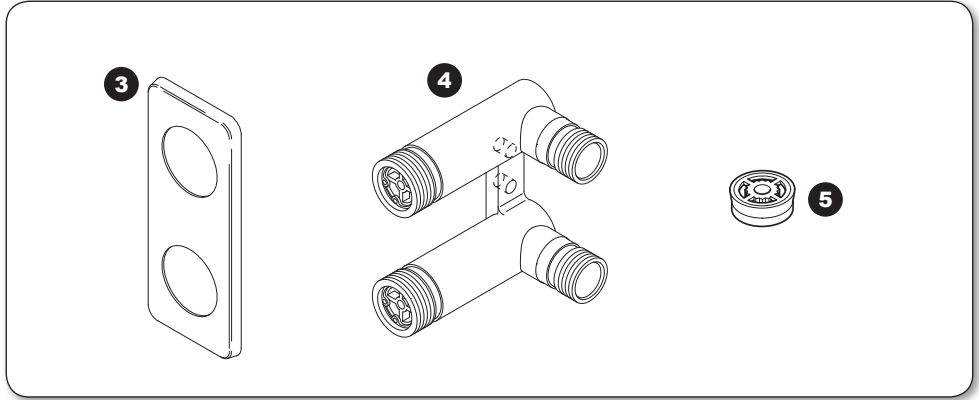

<b>Ref.</b>	<b>Description</b>	<b>Part No.</b>
3.	Coverplate	86003420
4.	Inlet mounting bracket	86003410
5.	Flow regulators are available from Triton at the following ratings:	
	(3 Ltr/min)	22010310
	(4 Ltr/min)	22011740
	(5 Ltr/min)	22011750
	(6 Ltr/min)	22011760
	(7 Ltr/min)	22011610
	(8 Ltr/min) Supplied	22011280

### MAINTENANCE

The following maintenance procedure must be carried out for commercial and health care premises, but is not necessarily required for domestic installations.

Maintenance of the unit is required to give continued performance after installation and that it continues to provide scald prevention.

Note: A thermostatic mixing valve in need of maintenance can be undetectable in normal use and only becomes apparent when a disruption occurs in the hot or cold water supply temperatures or pressures.

The frequency of routine maintenance of the internal of the valve will depend mainly on the water supply condition. Experience of local conditions will dictate the intervals for inspection and in-service testing; guidance has been given below which can be adjusted for local requirements.

- a) Initially check the filters for debris once every three months and clean if necessary.
- b) Perform a thermal shut off test every three months, and check the maximum temperature setting. See the 'Commissioning' section for the details of this test and readjustment of the maximum temperature setting if required.
- c) If the maximum water temperature varies by more than 2°C from the commissioned setting then carry out the following checks
  - Check the isolating valves are fully open.
  - Check the internal surface for scaling.

If the body requires descaling then it should be removed from the pipework to carry this work out (all rubber parts must be removed before descaling).

- Check the function of the non-return valves

The non-return valves (NRVs) prevent cross-flow between hot and cold supplies under unequal pressure conditions. They are designed for long life with no maintenance.

If these checks do not highlight the reason for the temperature variation, then internal components will require replacement; please see the spare parts list.

### Cleaning

Triton recommends that all products are cleaned using warm, soapy water.

Do not use abrasive or aggressive chemical cleaning products as this may affect the product surface finish and invalidate your guarantee.

### Cleaning the filters (fig.B)

It is advised that this should be carried out by a qualified person.

- Turn off the water supplies before starting.
- Remove the mixer from the mixer bracket.
- Remove the retaining clips in the hot and cold inlets.
- Remove the non return valve and filter.
- Wash the filter thoroughly under running water, use a suitable brush to remove all debris.
- Reassemble in reverse order.

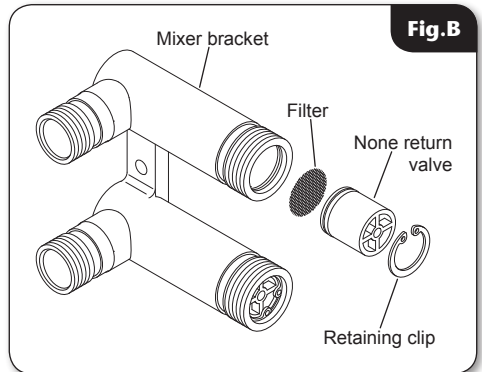

### Disinfection

Where chlorine is used for the disinfection of water systems all relevant guidelines and approved codes of practice must be strictly followed. Failure to comply with the relevant guidelines and approved codes of practice may invalidate your guarantee.

### WARNING!

**DO NOT use 'powerful' abrasive or solvent cleaning fluids when cleaning the shower as they may damage the fittings.**

**FAULT FINDING**

**The following can be carried out by a competent person**

<b>Problem/Symptom</b>	<b>Cause</b>	<b>Action/Cure</b>
<b>1</b> Water too hot.	<b>1.1</b> Temperature control incorrectly commissioned.	<b>1.1.1</b> Refer to commissioning section.
	<b>1.2</b> Not enough cold water flowing through shower.	<b>1.2.1</b> Reposition temperature control knob
	<b>1.3</b> Increase in the ambient cold water temperature.	<b>1.3.1</b> Reposition temperature control knob.
	<b>1.4</b> Cold water supply blocked.	<b>1.4.1</b> Turn off the shower and consult a competent plumber or contact Triton Customer Service.
	<b>1.5</b> High volume of cold water drawn off elsewhere.	<b>1.5.1</b> Reduce the simultaneous demand from the supply.
<b>2</b> Water too cold.	<b>2.1</b> Temperature control incorrectly commissioned.	<b>2.1.1</b> Refer to 'commissioning' section.
	<b>2.2</b> Not enough hot water flowing through shower.	<b>2.2.1</b> Reposition temperature control knob
	<b>2.3</b> Decrease in the ambient cold water temperature.	<b>2.3.1</b> Reposition temperature control knob
	<b>2.4</b> Insufficient hot water supplies from the heating system.	<b>2.4.1</b> Make sure heating appliance is set to maximum or has sufficient stored hot water.
		<b>2.4.2</b> Make sure heating appliance is igniting by trying a hot water tap elsewhere.
	<b>2.5</b> Hot water supply blocked or restricted.	<b>2.5.1</b> Turn off shower and consult a competent plumber or contact Triton Customer Service.
	<b>2.6</b> Flow regulator not fitted (HP systems only).	<b>2.6.1</b> Contact customer service.
<b>3</b> High water flow and/or poor performance on a mains fed system.	<b>3.1</b> Flow regulator not fitted.	<b>3.1.1</b> See page 11.

**FAULT FINDING**

<b>Problem/Symptom</b>	<b>Cause</b>	<b>Action/Cure</b>
<b>4</b> Water does not flow or shower pattern collapses when another outlet is turned on.	<b>4.1</b> Water supplies cut off.	<b>4.1.1</b> Check water elsewhere in house and if necessary contact local water company.
	<b>4.2</b> Shower unit blocked.	<b>4.2.1</b> Inspect the inlet filters. Clean if necessary.
	<b>4.3</b> Blockage in pipework.	<b>4.3.1</b> Turn off the shower and consult a suitably competent plumber.
	<b>4.4</b> Showerhead blocked.	<b>4.4.1</b> Clean showerhead.
	<b>4.5</b> System not capable of supplying multiple outlets at the same time.	<b>4.5.1</b> Reduce the simultaneous demand. <b>4.5.2</b> Make sure stop/service valves are fully open. <b>4.5.3</b> Check if sufficient water pressure.

**The following is recommended for a professional qualified installer only**

<b>5</b> Water too cold.	<b>5.1</b> Running pressure in excess of maximum recommended.	<b>5.1.1</b> Fit a pressure reducing valve.
<b>6</b> Shower controls noisy while in use.	<b>6.1</b> Running pressure in excess of maximum recommended.	<b>6.1.1</b> Fit a pressure reducing valve.
<b>7</b> Shower will not shut off.	<b>7.1</b> Flow control cartridge worn.	<b>7.1.1</b> Renew flow control cartridge.



## UK SERVICE POLICY

In the event of a product fault or complaint occurring, the following procedure should be followed:

1. Telephone Customer Service on **0844 980 0750** having available, your details including post code, the model number and power rating of the product, together with the date of purchase.
2. Based on information given over the telephone, a Triton Customer Service Advisor will attempt to diagnose the fault and confirm whether a site visit from a qualified service engineer is required.
3. All products attended to by a Triton service engineer must be installed in full accordance with the Triton installation guide applicable to the product. (*Every product pack contains an installation guide, however, they can also be bought via our Customer Service Spares Department.*)
4. Our engineer will require local parking and if a permit is required this must be available to the engineer on arrival at the call.
5. It is essential that you or an appointed representative (*who must be over 18 years of age*) is present for the duration of the service engineer's visit. If the product is in guarantee you must produce proof of purchase.
6. Where a call under the terms of guarantee has been booked and the failure is not product related (*i.e. scaling and furring, incorrect water pressure, pressure relief device operation or electrical/plumbing installation fault*) a charge will be made. A charge will also be issued if nobody is at home when the service engineer calls or adequate parking/permit is not available.
7. If the product is no longer covered by the guarantee an up front fixed fee will be charged before the site visit.
8. Should proof of purchase not be available on an "in-guarantee" call, or should the service engineer find that the product is no longer under guarantee, the engineer will charge the same fixed price and the customer will be expected to pay the engineer before he leaves. If payment is not made on the day an administration charge will be added to the fixed charge.
9. If a debt is outstanding from a previous visit, or from any other Triton purchase. Triton reserves the right to withhold service until the debt has been settled.
10. Triton takes the health, safety and wellbeing of its employees very seriously and expects customers to treat all staff members with respect. Should any employee feel threatened or receive abuse, either verbally or physically, Triton reserves the right to withhold service and will support the employee with a legal prosecution.

## Replacement Parts Policy

**Availability:** It is the policy of the manufacturer to maintain parts availability for the duration of production and a period of five years thereafter, in accordance with industry standards.

Spare parts are available via our website, [www.tritonshowers.co.uk](http://www.tritonshowers.co.uk), or by telephoning Triton Customer Service Spares Department. Payment should be made by credit/debit card (*excluding American Express or Diners Card*).

Payment can also be made by pre-payment of a pro forma invoice by cheque or money order.

## TRITON STANDARD GUARANTEE

Triton guarantee this product against all mechanical defects arising from faulty workmanship or materials for a period of five years for domestic use only, from the date of purchase, provided that it has been installed by a competent person in full accordance with the fitting instructions.

Any part found to be defective during this guarantee period we undertake to repair or replace at our option without charge so long as it has been properly maintained and operated in accordance with the operating instructions, and has not been subject to misuse or damage.

This product must not be taken apart, modified or repaired except by a person authorised by Triton. This guarantee applies only to products installed within the United Kingdom and does not apply to products used commercially. This guarantee does not affect your statutory rights.

### What is not covered:

1. Breakdown due to: **a)** use other than domestic use by you or your resident family; **b)** wilful act or neglect; **c)** any malfunction resulting from the incorrect use or quality of electricity, gas or water or incorrect setting of controls; **d)** failure to install in accordance with this installation guide.
2. Repair costs for damage caused by foreign objects or substances.
3. Total loss of the product due to non-availability of parts.
4. Compensation for loss of use of the product or consequential loss of any kind.
5. Call out charges where no fault has been found with the appliance.
6. Call out charges where the water supply cannot be isolated, this includes consequential losses arising from unserviceable supply valves.
7. The cost of repair or replacement of pressure relief devices, showerheads, hoses, riser rails and/or wall brackets, isolating switches, electrical cable, fuses and/or circuit breakers or any other accessories installed at the same time.
8. The cost of routine maintenance, adjustments, overhaul modifications or loss or damage arising therefrom, including the cost of repairing damage, breakdown, malfunction caused by corrosion, furring, pipe scaling, limescale, system debris or frost.

Triton Showers  
Triton Road  
Nuneaton  
Warwickshire CV11 4NR

*Triton is a division of Norcross Group (Holdings) Limited*

**Customer Service:** ☎ **0844 980 0750**

**Trade Installer Hotline:** ☎ **0844 980 0730**

**Fax:** **0844 980 0744**

[www.tritonshowers.co.uk](http://www.tritonshowers.co.uk)

**E-mail:** [serviceenquiries@tritonshowers.co.uk](mailto:serviceenquiries@tritonshowers.co.uk)